

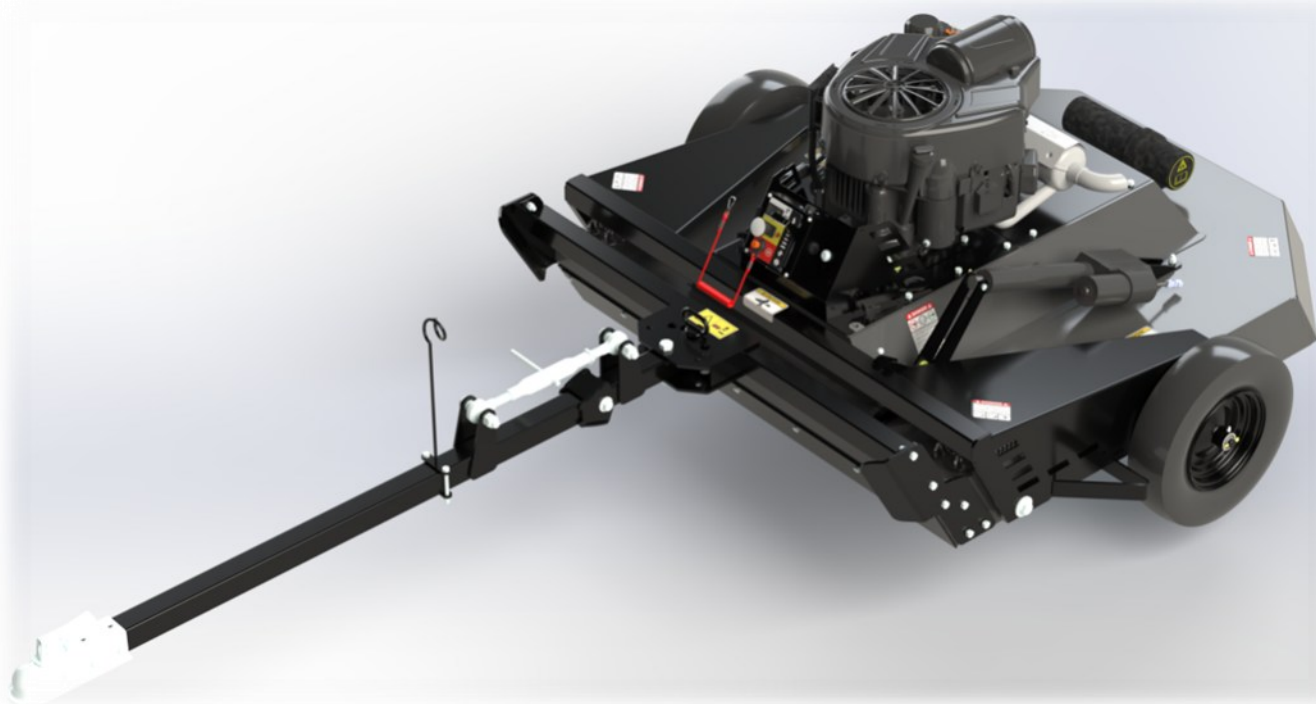

**OWNER'S MANUAL  
MODEL NUMBER**

**701207**



**BERCO  
ROUGH CUTTER 44" 20HP**

- \* ASSEMBLY
- \* OPERATION
- \* REPAIR PARTS
- \* MAINTENANCE

**CAUTION:**  
READ & FOLLOW ALL SAFETY RULES & INSTRUCTIONS BEFORE  
OPERATING YOUR EQUIPMENT



# TABLE OF CONTENTS

INTRODUCTION .....	1
IMPORTANT SAFETY INFORMATION .....	2
SAFETY ALERT SYMBOL / SIGNAL WORDS / SAFETY MESSAGES .....	2
SAFETY MESSAGES .....	2
SAFETY DECALS .....	5
ASSEMBLY .....	7
VEHICLE REQUIREMENTS .....	7
RECEPTION .....	7
ROUGH CUTTER ASSEMBLY .....	7
TOW BAR ASSEMBLY .....	7
TOW BAR INSTALLATION .....	8
REMOVE THE ROUGH CUTTER FROM THE WOOD BASE / INSTALLING THE BATTERY .....	9
CONTROL BOX INSTALLATION .....	11
VEHICLE MOUNTING AND DISMOUNTING .....	13
PREPARATION FOR MOUNTING .....	13
MOUNTING ON THE VEHICLE .....	13
DISMOUNTING THE VEHICLE .....	13
OPERATION .....	14
SAFETY PRECAUTIONS .....	14
CONTROL AND DISPLAY .....	16
PRE-OPERATION INSPECTIONS .....	17
OPERATION INSTRUCTIONS .....	18
ENGINE STARTING .....	18
BLADE ENGAGEMENT AND DISENGAGEMENT .....	18
SHUTDOWN PROCEDURE .....	19
EMERGENCY STOP .....	19
CLUTCH BURNISHING .....	19
BELT RUNNING IN .....	19
CLEANING UP A BLOCKAGE .....	19
CUTTING OPERATION .....	20
ADJUSTMENTS .....	22
DECK LEVEL ADJUSTMENT .....	22
CUT HEIGHT ADJUSTMENT .....	22
TOW HITCH OFFSET .....	22
MAINTENANCE .....	23
MAINTENANCE SCHEDULE .....	23
BLADE MAINTENANCE .....	24
INSTALLATION / REPLACEMENT OF THE BLADES .....	24
BLADE SHARPENING .....	25
BELT REPLACEMENT .....	25
BELT TENSION ADJUSTMENT .....	25
IMPORTANT TIGHTENING TORQUES .....	26
TRANSPORTATION .....	27
TO TRANSPORT .....	27
DISMOUNTING AND STORAGE .....	27
DISMOUNTING .....	27
LONG-TERM STORAGE .....	27
SPECIFICATIONS .....	28
TROUBLESHOOTING .....	29
PARTS BREAKDOWN AND PARTS LIST .....	33
TORQUE SPECIFICATION TABLE .....	56
WARRANTY .....	57

# INTRODUCTION

## TO THE PURCHASER

This new accessory was carefully designed to give years of dependable service. This manual has been provided to assist in the safe operation and servicing of your attachment.

**NOTE:** All photographs and illustrations in the manual may not necessarily depict the actual models or attachment, but are intended for reference only and are based on the latest product information available at the time of publication.

Familiarize yourself fully with the safety recommendations and operating procedures before putting the machine to use. Carefully read, understand and follow these recommendations and insist that they be followed by those who will use this attachment.



**THIS SAFETY ALERT SYMBOL IDENTIFIES AN IMPORTANT SAFETY MESSAGE IN THIS MANUAL THAT HELPS YOU AND OTHERS AVOID PERSONAL INJURY OR EVEN DEATH. DANGER, WARNING, AND CAUTION ARE SIGNAL WORDS USED TO IDENTIFY THE LEVEL OF HAZARD. HOWEVER, REGARDLESS OF THE HAZARD, BE EXTREMELY CAREFUL.**

**DANGER:** Signals an extreme hazard that will cause serious injury or death if recommended precautions are not followed.

**WARNING:** Signals a hazard that may cause serious injury or death if the recommended precautions are not followed.

**CAUTION:** Signals a hazard that may cause minor or moderate injury if the recommended precautions are not followed.

Record your attachment serial number and purchase date in the section reserved below (there is no serial number on the subframe). Your dealer requires this information to give you prompt, efficient service when ordering replacement parts. Use only genuine parts when replacements are required.

If warranty repairs are required please present this registration booklet and original sales invoice to your selling dealer for warranty service.

**This manual should be kept for future reference.**

**Please check if you have received all the parts for your kit with the list of the bag and the list of the box.**

**SERIAL NUMBER :** \_\_\_\_\_  
(IF APPLICABLE)

**MODEL NUMBER:** \_\_\_\_\_

**PURCHASE DATE :** \_\_\_\_\_

### **INTENDED USE:**

The 44" rough cutter is designed for clearing dense grass areas and cutting young trees in meadows and small properties. It is not intended for creating a finishing cut on lawns. The rough cutter should be towed behind an ATV, golf cart, tractor, or other approved vehicle using a 2" (50mm) ball hitch. It is not recommended for speeds exceeding 5 mph (8 km/h).

# IMPORTANT SAFETY INFORMATIONS

## Safety alert symbol/Signal words/Safety messages

These are common practices that may or may not be applicable to the product described in this manual.

### SAFETY ALERT SYMBOL



**THIS SAFETY ALERT SYMBOL IDENTIFIES AN IMPORTANT SAFETY MESSAGE IN THIS MANUAL THAT HELPS YOU AND OTHERS AVOID PERSONAL INJURY OR EVEN DEATH. DANGER, WARNING, AND CAUTION ARE SIGNAL WORDS USED TO IDENTIFY THE LEVEL OF HAZARD. HOWEVER, REGARDLESS OF THE HAZARD, BE EXTREMELY CAREFUL.**

- ⚠ DANGER:** Signals an extreme hazard that will cause serious injury or death if recommended precautions are not followed.
- ⚠ WARNING:** Signals a hazard that may cause serious injury or death if the recommended precautions are not followed.
- ⚠ CAUTION:** Signals a hazard that may cause minor or moderate injury if the recommended precautions are not followed.

### PREPARATION FOR USE

All operators, no matter how experienced they may be, should read and understand this and other manuals related to the vehicle and accessory before operating. It is the owner's legal obligation to instruct all operators in safe operation of the accessory to prevent injury or death. Improper use of the accessory can cause serious injury or death.

- Read and understand this owner's manual carefully. Be thoroughly familiar with the controls and proper use of the vehicle and accessory. Know how to stop the unit and handle the controls quickly in case of emergency.
- Read and understand the "Safety Decals" section, read all instructions noted on them or/and in the "Safety Decals" section.
- Never allow children to operate the vehicle nor the accessory. Never allow adults to operate or maintain the vehicle nor the accessory without proper instructions. Local regulations restrict the age of the operator.
- Children are often attracted to accessories. Never assume children will stay in place where you have last seen them. Keep children under surveillance of a responsible adult at all times.
- No one should operate the vehicle nor the accessory while intoxicated or while taking medication that impairs the senses or reactions. The operator should, if taking medication, seek

medical advice on whether he/she can safely operate the equipment.

- Keep the area of operation clear of all people, particularly small children.
- Never start or operate the accessories except from the operator's seat.
- Prepare for emergencies. Be prepared if a fire starts. Keep first aid kit and fire extinguisher handy. Keep emergency phone numbers (doctor, ambulance, etc) near a phone.
- Thoroughly inspect the area where the accessory is to be used and remove door mats, wires, and other foreign objects .
- For motorized accessories, disengage all clutches and shift into neutral before starting engine.
- Do not operate or maintain the accessory without wearing adequate clothing and safety equipment. (glasses, muffs, earplugs, mask...) Wear footwear that will improve footing on slippery surfaces. Prolonged exposure to loud noise can cause hearing impairment or hearing loss.
- Clothing should be snug without fringes and pull strings to avoid entanglement with moving parts.
- Avoid wearing radio headphones while operating.

## IMPORTANT SAFETY INFORMATIONS

- Handle fuel with care, it is highly flammable and vapors are explosive.
  - a) Extinguish all cigarettes, cigars, pipes and other sources of ignition.
  - b) Use approved fuel container.
  - c) Never add fuel to a running engine or hot engine.
  - d) Fill fuel tank outdoors with extreme care. Never fill fuel tank indoors.
  - e) Never fill containers inside a vehicle, on a truck or a trailer bed with a plastic liner. Always place containers on the ground, away from your vehicle, before filling.
  - f) When possible, remove gas-powered equipment from the truck or trailer and refuel it on the ground. If this is not possible, then refuel such equipment on a trailer with a portable container, rather than directly from a gasoline dispenser nozzle.
  - g) Keep the nozzle in contact with the rim of the fuel tank or container opening at all times, until refueling is complete. Do not use a nozzle lock-open device.
  - h) Never overfill fuel tank. Replace fuel cap securely and wipe up spilled fuel.
  - i) If fuel is spilled on clothing, change clothing immediately.
- Never attempt to make any adjustments while the engine (motor) is running (except when specifically recommended by manufacturer).
- Let the vehicle and accessory adjust to outdoor temperatures before using.
- Always make sure to have safe traction on the vehicle by using the recommended accessories (chains, tracks, counterweights...). See operation section.
- Always make sure all components are correctly installed. (driveline securely attached and locked at both ends, belts properly installed...)
- Never modify the accessory or any part without the written consent from the manufacturer. Use only options/accessories approved by the manufacturer
- Avoid underground utilities. If the accessory digs into the ground, always contact your local utility companies (electrical, water, gas,...) before digging to know where you can dig.
- Exercise extreme caution when operating on or crossing gravel drives, walks or roads. Stay alert for hidden hazards such as traffic, fences, trees, buildings, wires, etc.
- After striking a foreign object, stop the engine (motor), disconnect the wire from the spark plug(s) and keep wire away to prevent accidental starting. Thoroughly inspect the accessory for any damage and repair damage before restarting and using the accessory.
- If the unit should start to vibrate abnormally, stop the engine (motor) and check immediately for the cause. Vibration is generally a warning of trouble. Do not use equipment until properly repaired.
- Take all possible precautions when leaving the operator's seat. Disengage the power take-off, lower the accessory, place the transmission into neutral, set the parking brake, stop the engine and remove the ignition key to prevent unauthorized starting then wait for all components to come to a complete stop before leaving operator's seat.
- Do not run the engine indoors, except when starting the engine and for transporting in or out of the building. Do not operate or let motor run in a storage area without ventilation because gas contains carbon monoxide which is odorless, colorless and can cause death.
- Never use the accessories across the face of slopes. Go from top to bottom. Exercise extreme caution when using equipment on slopes, on wet ground or near a drop-off. Do not attempt to use accessory on a steep slope.
- Never tolerate bystanders in the working zone or between the vehicle and accessory while hooking-up the accessory.
- Never operate the accessory at high transport speeds. Move and turn vehicle at low speeds during operation. Be cautious when backing up.
- Do not carry or lift passengers on vehicle or accessory.
- Disengage power to the accessory when it is transported or not in use.
- Never operate the accessory without good visibility or light.
- Keep the accessory away from heat sources or flames.
- Never use accessory if it has been dropped or damaged. Repair if necessary before re-using.
- Never use an accessory without proper guards, plates, or other safety protective devices in place

### OPERATION:

- Do not put hands or feet near, under or inside rotating parts or any power driven parts

# IMPORTANT SAFETY INFORMATIONS

## TRANSPORT

- Review Transport Safety instructions in the vehicle manual before moving or hauling.
- Check with local authorities regarding transport on public roads and off road. Comply to all applicable laws and regulations.
- Make sure all lights and reflectors that are required by the local highway and transport authorities (exemple : SMV (Slow Moving Vehicle), flashing warning light) are in place, are clean, and can be seen clearly by all overtaking and oncoming traffic. Turn on flashing warning light whenever on a highway, except where such is prohibited by law.
- Never have the equipment in operation during transport.
- Always travel at a safe and slow speed to allow adequate steering control and stopping
- Always drive with accessory low to the ground but high enough to avoid any contact with road or any foreign objects during transportation
- Avoid any contact with any overhead power line.
- Never drive the accessories across the face of slopes. Go from top to bottom or bottom to up
- Engage parking brake when stopped on an incline
- Allow for the accessory length when making turns.

## MAINTENANCE AND ADJUSTMENT

- When cleaning, repairing or inspecting the vehicle and accessory: park on a solid level ground (in a clean dry area), disengage drives, lower implement, set parking brake, stop the engine, remove ignition key, and wait that all moving parts have stopped and cooled. For gasoline engine, disconnect wire from the spark plug(s) and keep wire away to prevent accidental starting.
- Allow the accessory to cool before working on it
- Use a jack and support blocks to support equipment when required. Carefully release pressure from equipment with stored energy.
- Check all the bolts and components at frequent intervals to make sure that they are properly tightened and in safe working condition.
- When inflating tires, stand on one side NOT in front or over the tire assembly. Use a safety cage if available.
- Remove grease, oil, or debris build-ups.

Remove all tools and unused parts from equipment before operation.

- Disconnect battery ground cable (-) before servicing or adjusting electrical systems or before welding on implement
- Replace parts on this accessory with genuine part only.
- Understands maintenance and adjustment procedure, see adjustment and maintenance section of the owner's manual.
- Never work or walk under the accessory unless securely blocked. Otherwise accessory can fall.
- Visually check for hydraulic leaks and broken, missing, or malfunctioning parts and make necessary repairs before applying pressure to the system. Do the same validation after applying pressure to the system (use a piece of cardboard not your hands to detect leaks).
- Escaping hydraulic oil under pressure can have sufficient force to penetrate skin, causing serious personal injury. If injured by escaping fluid, obtain medical treatment immediately.
- Wear protective gloves and safety glasses or goggles when working with hydraulic system.
- Before disconnecting hydraulic line or performing work, relieve all hydraulic pressure

## STORAGE

- Never store a motorized accessory with fuel in the fuel tank inside a building where ignition sources are present such as hot water and space heaters, clothes dryers, and the like. Allow the engine to cool before storing in any enclosure.
- Always refer to the owner's manual when you store the accessory and vehicle for a prolonged or an unspecified length of time.
- Maintain or replace safety and instruction labels, as necessary.
- For winter accessories, (if applicable), let the engine run for a few minutes after clearing snow in order to prevent the rotary parts from freezing.
- Always refer to operator's manual for important details if the accessory is to be stored for an extended period
- Store the accessory in an area where children normally do not play. Secure the implement using blocks and supports and secure any pointy or sharp edges.



# SAFETY DECALS



Read and understand all instructions/explanations noted on the decals and/or in the "Safety Decals" section.

- Keep safety decals clean and legible.
- For decal locations, see the Parts List section of this manual.
- Replace decals if they are damaged or illegible.
- To purchase new decals, see the back of this manual for contact information in the introduction section.
- To install new decals:
  - Thoroughly clean the area where the decal will be installed (remove all grease, rust, dust, etc.).
  - Peel the decal tape off and install it in the correct location (see parts list), pressing it firmly.
  - Remove any bubbles from under the decal.



Decal #107584



Decal #105946

**Caution:** Pinch point.

To avoid serious injury, stay away from moving parts.



Decal #105128



Decal #107585



# SAFETY DECALS



Decal #108301  
Do not step.

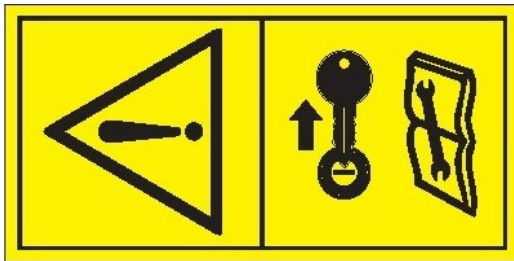

Decal # 108556  
Before doing any maintenance:  
Remove key from ignition, locate, read  
and make sure to understand all of the  
owner's manual.



Decal #110297  
Be careful of pinch points, do not put  
hands or any other part of the body into  
moving parts.

## IMPORTANT

### STALE GAS IS A MAJOR CAUSE OF ENGINE FAILURE

Gas will become stale if you are storing your power equipment for more than 30 days. Stale fuel can cause engine damage from acid and gum deposits forming in the fuel system or carburetor.

Keep gas fresh by using proper fuel stabilizer.

Read and understand your engine manual for all requirements.

### UN CARBURANT ÉVENTÉ EST UNE DES CAUSES PRINCIPALES DES BRIS DE MOTEURS

Le carburant s'évente lorsqu'il est stocké plus de 30 jours. Un carburant éventé entraîne des dépôts acides et de résidus de gomme dans le système de carburant ou sur des pièces essentielles du carburateur.

Pour conserver le carburant en bon état, utiliser le stabilisateur de carburant adéquat.

Lire et comprendre le manuel d'utilisation de votre moteur pour toutes les exigences.

108261

Decal #108261  
Fuel recommendations to avoid engine break-downs.

# ASSEMBLY

## REQUIREMENTS FOR THE VEHICLE TO WHICH THE ROUGH CUTTER IS ATTACHED

- Ensure you comply with the specified towing capacity of the towing vehicle. See the "SPECIFICATIONS" section of this manual for brush cutter specifications.
- The vehicle must be in good condition and all safety equipment must be present and functional (refer to the vehicle manual).
- The vehicle must be equipped with a 2" (50mm) tow ball.
- The vehicle is a 4-wheel drive ATV/UV.

## RECEPTION:

1. Remove the protective cover from the wooden box.
2. Cut the nylon strapping holding the cardboard box.
3. Remove the cover and the four panels from the wooden box.
4. Remove the cardboard box and remove the pull bar from the side panel.
5. Proceed with the assembly of the rough cutter (see next section)

**IMPORTANT:** Leave the rough cutter attached to the bottom of the wooden box for now.

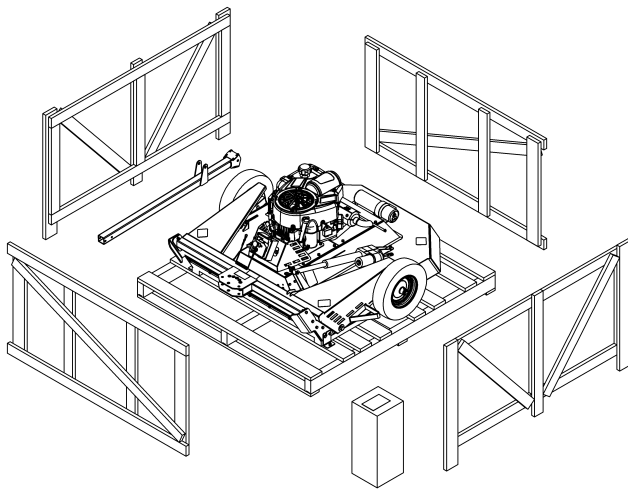

**IMPORTANT:** The engine does not have oil when shipped from the factory, so **PUT OIL IN THE ENGINE BEFORE STARTING IT FOR THE FIRST TIME.** Refer to the engine manual located in the manual box on the rough cutter.

## ROUGH CUTTER ASSEMBLY



### WARNING



#### THIS ACCESSORY IS HEAVY! TO AVOID RISK OF STRAIN INJURY

- NEVER lift the accessory by hand alone when handling the components or assembly.
- Use proper lifting device and seek assistance.
- When accessory is off the ground, NEVER be underneath the accessory.
- Serious injury including possibility of death could occur if accessory were to drop suddenly.
- Always wear protective shoes and appropriate gloves when manipulating or using this equipment.
- Ensure the accessory is stable at all times.

- Unless otherwise specified, tighten all bolts according to the torque specification table (see table of contents for page number).
- Refer to the Parts List section (at the end of this manual) for the identification of each part.
- **NOTE:** In this manual, the right and left side are determined by sitting in the driver's seat.

## A) TOW BAR ASSEMBLY

- 1) Install the hitch (item 1) to the pull bar (item 2) using two hex. bolts 3/8" n.c. x 3" (item 3) and two nylon insert lock nuts 3/8" n.c. (item 4).

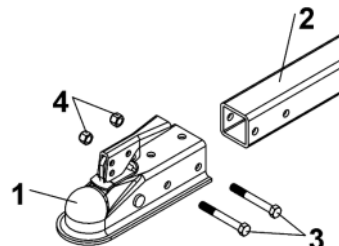

# ASSEMBLY

2) Install the rear hitch bar (item 1) on the pull bar (item 2) with one hex. bolt 1/2" n.c. x 3 1/2" (item 3) two flat washers 1/2" hole (item 4), the sleeve (item 5) and one nylon insert lock nut 1/2" n.c. (item 6). Do not tighten firmly as to let the hitch pivot.

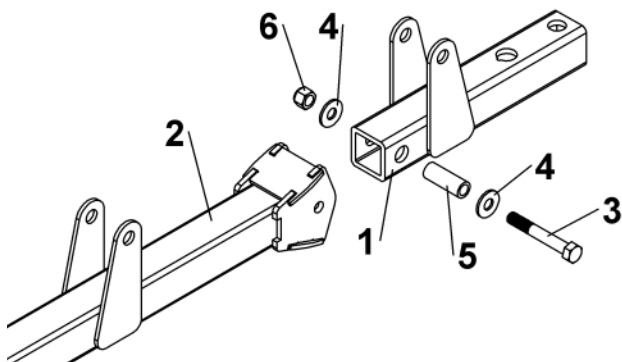

3) As illustrated, install the top link (item 1) to the hitch bars (item A) using two hex. bolts 5/8" n.c. x 3 1/2" (item 2), four sleeves (item 3) nylon insert lock nut 5/8" n.c. (item 4).

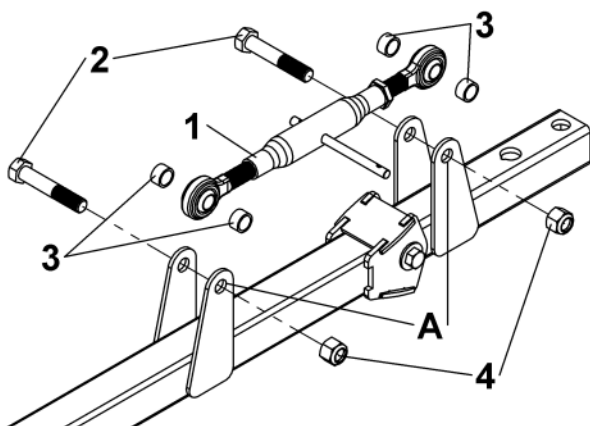

4) Adjust the top link (item 1) to 13 1/2" center to center to obtain a horizontal tow bar (item 2).

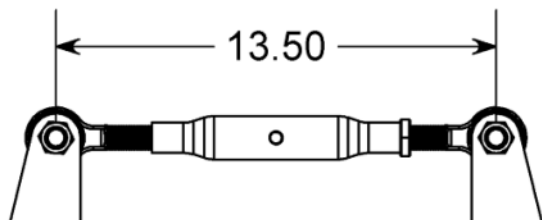

## B) TOW BAR INSTALLATION

1) Insert the sleeve (item 1) into the corresponding hitch bar hole (item 2).

Align holes and install, as shown, the hitch bar assembly (item 2) with the sleeve on the rough cutter assembly (item 3) using a hex. bolt 5/8" n.c. x 3 1/2" (item 4) and a nylon insert lock nut 5/8" n.c. (item 5).

Finally, secure the position of the hitch bar with the pin with hair pin 4mm (item 6).

See "ADJUSTMENT" section to select the proper hitch bar orientation for the application.

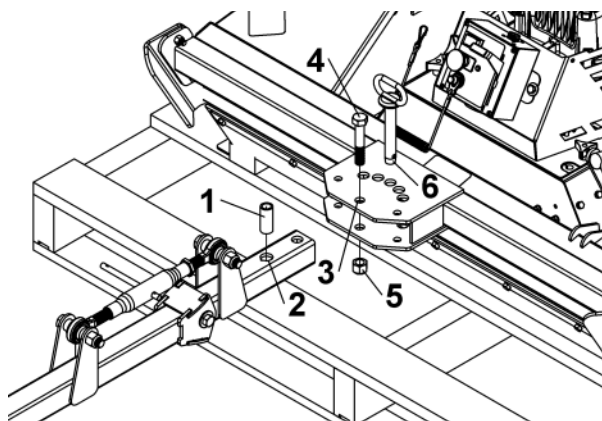

2) Install the cable holder (item 1) on the intermediate hitch bar (item A) with the support plate (item 2), two hex bolts 5/16" n.c. x 3" (item 3) and two nylon insert lock nuts 5/16" n.c. (item 4).

**NOTE:** Position the cable holder near the top link. You may re-adjust this location to avoid any interference with the control cables while towing vehicle is in motion.

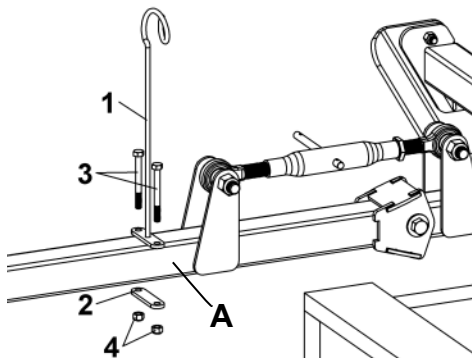

# ASSEMBLY

## C) REMOVE THE ROUGH CUTTER FROM THE WOODEN BASE AND INSTALLING THE BATTERY

1) Add oil in the engine. Verify oil level and add if necessary before starting engine. (See engine owner's manual).

2) Unbolt the two front brackets (item A) and the two rear brackets (item B). Dispose of the hardware.

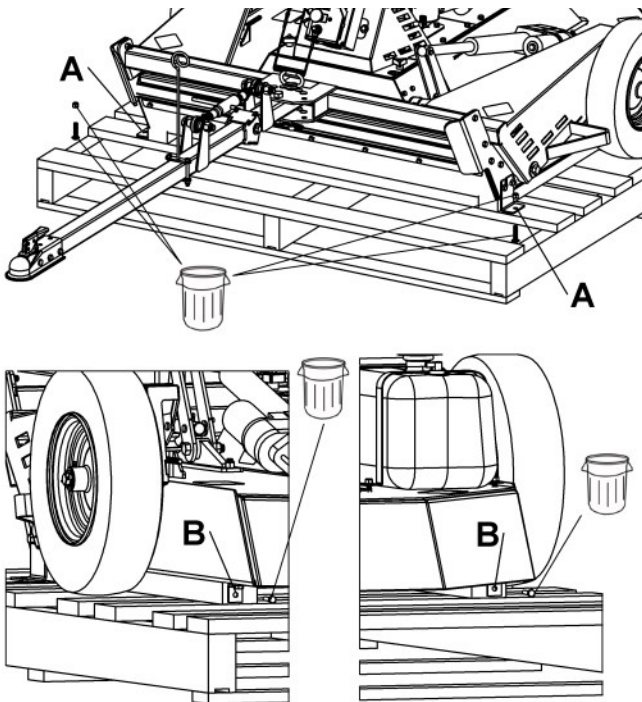

3) Disengage spark plugs wires and place it where it cannot make a connection.

4) Install the battery

### **U1 battery must be purchased locally:**

Check the battery. If the battery is put into service after the "month and year" of the date on the battery, it may need to be charged with a 12 volt battery charger. Follow the manufacturer's instructions for the battery or for the battery charger.



## WARNING



### TO PREVENT INJURY OR BREAKAGE:

- If there is an accidental splash of battery acid in the eyes or on the skin, rinse the affected area immediately with clean cold water. Consult a doctor quickly.
- If acid comes into contact with clothing, first dilute it with clean water, then neutralize with an ammonia/water or baking soda/water solution.
- NEVER connect (or disconnect) the clamps on the battery charger while the charger is on, as this may cause sparks.
- Keep all sources of ignition (cigarettes, matches, lighters) away from the battery. The gases generated during charging can be combustible.
- As a precaution, only charge the battery in a well-ventilated area.
- Always protect your eyes, skin and clothing when working near batteries.
- Batteries contain sulfuric acid and can emit explosive gases. Exercise extreme caution when handling batteries.
- Keep batteries out of the reach of children.
- Improper use of the battery may result in a risk of fire or chemical burn. **DO NOT** open, disassemble, overheat, or incinerate the battery.
- When connecting the battery cables, always connect the POSITIVE (red) cable to the corresponding terminal first, followed by the NEGATIVE (black) cable. This prevents sparks or electrical short circuit injuries that can occur if you touch the cables with tools while connecting them.
- Before handling the battery, be sure to remove all jewelry from your hand, as well as your watch. Metal objects that come into contact with the battery terminals can cause burns, electric shock, and short circuit of the battery.

# ASSEMBLY

To install the battery

- Remove knobs (item 1) and the guard assembly (item 2).
- Put the battery (item 3) in place.
- Attach battery cables to the battery, making sure to attach the red wire to the positive terminal (item 4) first and the black wire to the negative terminal (item 5) second.
- Put the assembled guard back in place with knobs.

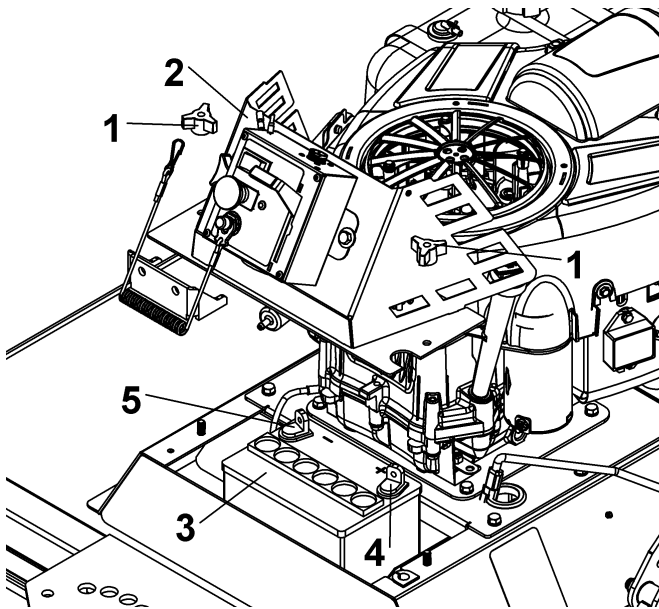

## WARNING



Clean hands thoroughly after assembling lead-containing battery wires, terminals, and other accessories.



## WARNING



### TO PREVENT INJURY OR DAMAGE:

It is very important to place the protective cover onto the battery's red terminal post.

5) Adjust the tire pressure to the maximum pressure indicated on the accessory tire. The tire pressure must be equal on both sides.

6) Adjust the rough cutter to its highest setting. (See the "ADJUSTMENTS" section for details.)

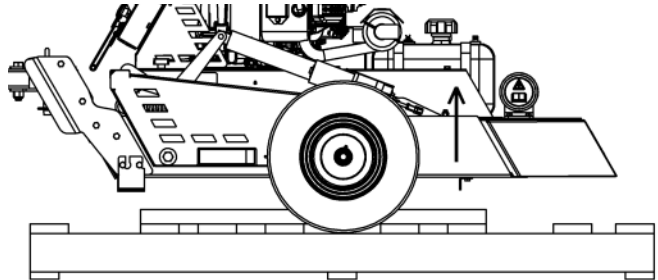

7) Remove the two front brackets (item A), by loosening the two bolts (item 1) on each bracket, and the two rear brackets (item B). Retighten the bolts (item 1). Dispose of the four brackets and the indicated hardware.

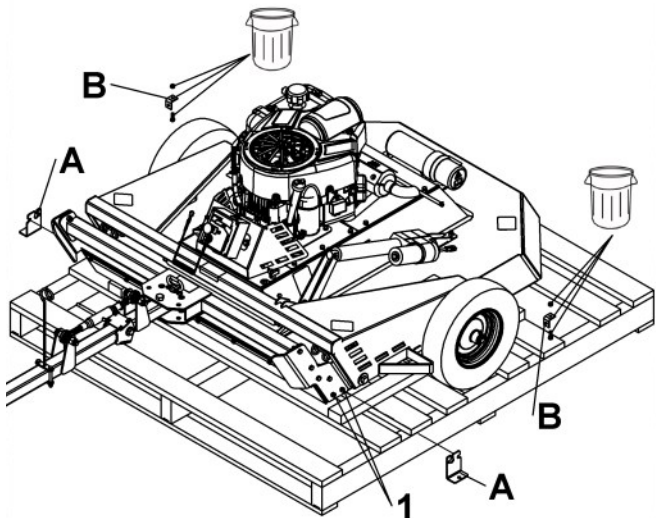

8) Install ramps (item A) (not supplied), hook up the vehicle (Refer to the "VEHICLE MOUNTING AND DISMOUNTING" section) and pull gently to lower the rough cutter from the base of the wooden box.

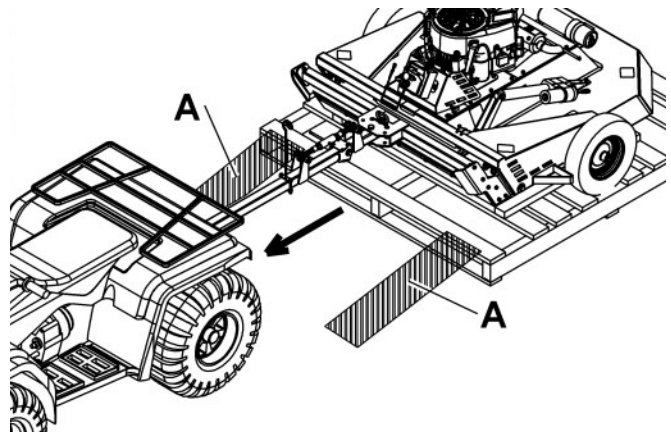

# ASSEMBLY

## D) CONTROL BOX INSTALLATION

1) Remove control box (item 1) from guard (item 2) by loosening the knob (item 3).

TIP: Replace the knob on guard and tighten securely to avoid loss of knob due to vibration while in use.

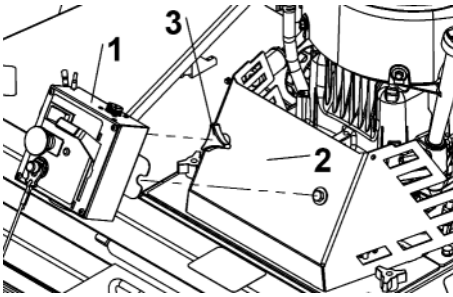

2) Install the o-ring (item 1) on the box support (item 2) using hex. bolt  $5/16''$  n.c. x  $3/4''$  (item 3), flat washer  $3/8''$  hole (item 4) and nylon insert lock nut  $5/16''$  n.c. (item 5).

Do not over tighten o-ring.

Use the slot (item A) on the control box to avoid over tightening and to make sure it is well inserted.

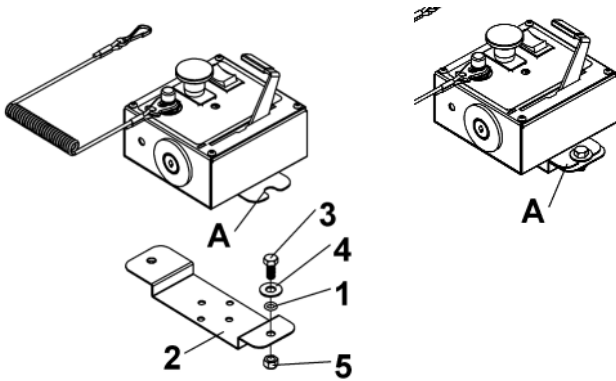

3) Choose option A or B to fix the control box support (item 1).

**NOTE:** In order to prevent damage due to water accumulation, make sure to place the control box horizontally.

### Option A

Use two hex bolts  $1/4''$  x  $1\ 1/2''$  (item 2), two spacers (item 3) and two flange nuts  $1/4''$  (item 4) to attach the control box support to the support brackets (item 5).

**NOTE:** Choose the right hole combination on the control box support in order to orient the front of the control box towards the driving controls of the vehicle. (see operation section to see how control box is oriented), Furthermore, make sure to have free access at all times to the equipment's controls in order to safely control the equipment.

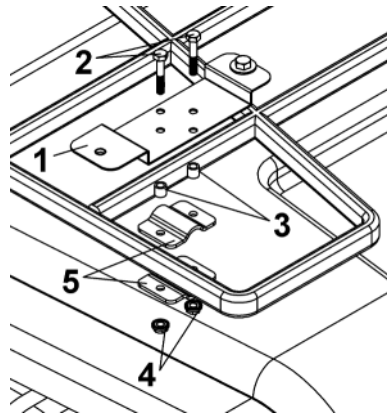

### Option B

Drill two holes of  $1\ 9/16''$  apart on the vehicle. Secure the control box support with two bolts  $1/4''$  x  $1/2''$  (item 6) and two flange nuts  $1/4''$ .

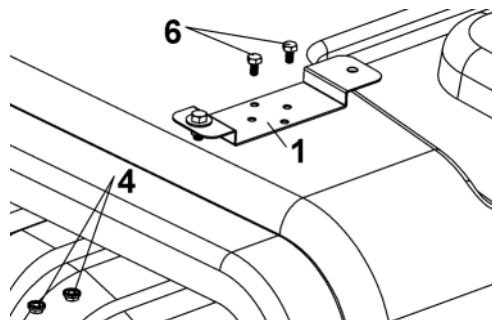

# ASSEMBLY

## INSTALL THE CONTROL BOX IN ITS SUPPORT

Put the control box (item 1) in its support (item 2).

Secure on place with the knob (item3).

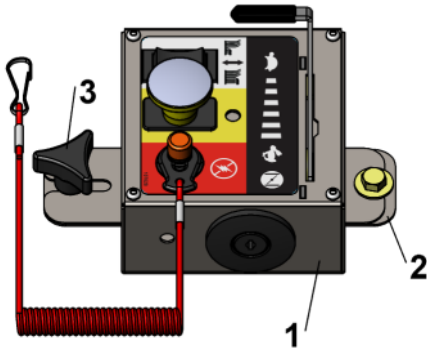

## SECURE CABLES.

Insert the cables (item 1) through the opening of the cable holder (item 2).

**IMPORTANT :** Be careful to secure the cables to avoid any damage caused by a contact with the vehicle, equipment itself (especially engine exhaust) or any other object that can be found in the area of these cables.

Attach the electrical cable and the engine control cable to the equipment and to the vehicle, if necessary use cable ties.

**Do not forget :** the control box must be easily removable from vehicle.

If needed, re-adjust the position of the cable support (item 2) to avoid any interference with the control cables while towing vehicle is in motion.

**IMPORTANT:** Before operating this equipment proceed with all the adjustments required in section « Adjustments ».

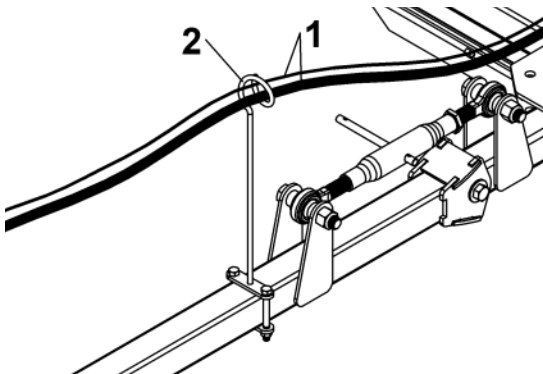

# VEHICLE MOUNTING AND DISMOUNTING

## PREPARATION FOR MOUNTING

Ensure that:

- The vehicle is equipped with a 2" (50mm) ball.
- The assembly of the rough cutter is completed (as in the assembly section).
- The rough cutter and the vehicle are on flat, hard ground.



**DANGER**



**TO PREVENT INJURIES AND DEATH  
Before any maintenance, assembly or  
disassembly of the accessory, always:**

- Make sure the accessory is disengaged.
- Make sure all moving parts are stopped.
- Make sure you are on a horizontal and firm surface.
- Apply the vehicle's parking brake.
- Stop the vehicle and remove the key.
- Stop the accessory's engine and remove the key from the ignition.
- Disconnect the wires from the spark plugs and keep it away from the spark plugs to prevent accidental starting.

## MOUNTING ON THE VEHICLE

1. Move the vehicle back to the desired towing position.
2. Stop the vehicle, apply the handbrake, remove the key.



**DANGER**



**TO PREVENT INJURIES AND DEATH:**

- Always check that ball is completely inserted into hitch coupler socket and that under jaw is securely closed around the bottom of ball.
- Always check that hitch coupler handle is properly locked before its use.
- Always examine hitch coupler and ball for damage before using, replace if damaged.
- Once in place apply force in all directions to ensure the hitch is installed correctly.

3. Install the hitch (item 1) on the tow hitch ball and secure in place with the hair pin
- To open: pull on the handle of the hitch coupler (item 1) and turn forward. Place the hitch coupler on the ball.
  - When the ball is fully inserted into the hitch coupler cavity, turn the handle back until the handle is locked in place.
  - Always check the tightening before using the tow hitch. Make sure the hitch coupler handle is in the locked position.
  - Lock the handle into position with the ball in the socket of the hitch. Tighten the lock nut (item 2) against the spring so that the hitch coupler is not loose on the ball.

**NOTE:** Correct adjustment will allow the handle to be released with moderate pressure applied to the handle.

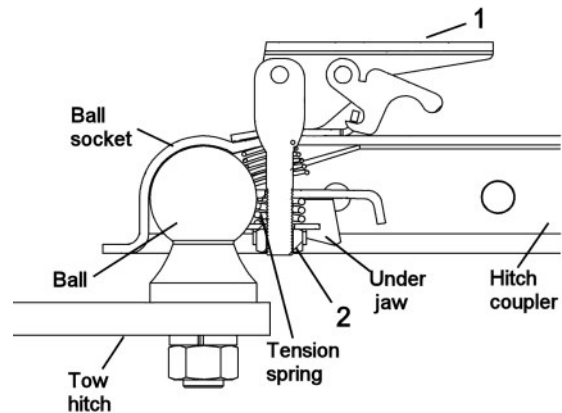

4. Install the control box (see section "ASSEMBLY" of this manual).
5. Refer to the "OPERATION" section for starting and operating the rough cutter.

## DISMOUNTING THE VEHICLE

1. Park the rough cutter and the vehicle on flat, hard ground
2. Stop the vehicle, apply the handbrake, remove the key.
3. Stop the rough cutter (see section "SHUTDOWN PROCEDURE" in the "OPERATION" section)
4. Remove the control box and the electrical harness and place on the rough cutter.
5. Remove the rough cutter attachment from the vehicle ball. For more details, follow the steps reversing installation on the ball in the "MOUNTING ON THE VEHICLE" section.
6. To store the rough cutter, see the section "STORAGE".

# OPERATION

## SAFETY PRECAUTIONS



### DANGER



#### TO PREVENT INJURIES AND DEATH:

It is absolutely essential that no one operates the rotating attachment without first having read, fully understood and become totally familiar with the manual. Accident prevention and risk control depend on the awareness, concern, caution and proper training involved in the operation, transport, storage and maintenance of the rotating attachment.



### DANGER



Tragic accidents can occur if the operator is not alert to the presence of children.

Children are often attracted to the equipment and the mowing activity. **Never assume that children will remain where you last saw them.**



### DANGER



**Before starting work:** Sit in the driver's seat and always attach the emergency switch lanyard to the control box.

**NEVER OPERATE WITHOUT THIS LANYARD.**



### DANGER



#### TO PREVENT INJURIES:

**Never place** hands or feet under the deck or attempt to make adjustments to the cutter with ELECTRIC CLUTCH engaged. Cutter blades rotating at high speeds cannot be seen and are located close to the deck housing. Body extremities can be cut off instantly.



### DANGER



#### TO PREVENT INJURIES:

All guards and protections must be installed and in good condition at all times during the cutting operation.



### DANGER



#### TO PREVENT INJURIES:

**Keep others away** while cutter is operating. **It can discharge objects at high speeds.** Therefore, the use of front and rear safety guards is strongly recommended when cutting along highways and in areas where people may be present. Stop blade rotation if a bystander is within at least **300 feet**.

Additionally, if the operator's position is not in a cabin, it is recommended to place a guard between the operator and the rough cutter.



### DANGER



#### TO PREVENT INJURIES:

**Never allow riders** including children on the vehicle or cutter.

They can fall and be ran over causing serious injury or death.



### DANGER



#### TO PREVENT INJURIES:

Do not operate and/or travel across **steep inclines** where a vehicle can rollover resulting in serious injury or death.

Consult your vehicle's manual for acceptable inclines the vehicle is capable of traveling across. Never operate on slopes of more than 15 degrees.



### DANGER



#### TO PREVENT INJURIES AND DEATH:

Operate with only one person, do not allow any person within a radius of 5 meters of the vehicle and the rough cutter. If one person is in the operator's position and another on the rough cutter, the person in the operator's position can activate the clutch which can cause serious injuries or even death to the person near the rough cutter.

# OPERATION



## DANGER



### TO PREVENT INJURIES:

Always disengage the clutch, engage the parking brake, stop the vehicle, remove the key, and wait until all moving parts of the rough cutter have stopped (wait more than 20 seconds) **before getting out of the vehicle.**



## DANGER



### TO PREVENT INJURIES:

Do not use cutter as a fan. Cutting blades are not properly designed or guarded for this use. Using cutter as a fan can result in injury or death.



## DANGER



### TO PREVENT INJURIES AND DEATH:

Before working under the cutting deck, always turn off the clutch, engage the emergency stop on the control box, stop the engine and remove the key, remove the spark plugs cable from the gasoline engine (and secure it properly) and disengage the drive belt from the engine pulley.



## DANGER



### TO PREVENT INJURIES AND DEATH:

Always wear the protective equipment indicated in your vehicle operator's manual. In addition to these instructions, always wear certified safety glasses, an approved ATV/UV helmet, and hearing protection.



## DANGER



### TO PREVENT INJURIES AND DEATH:

For offset use, always use on a level surface. On an uneven surface, the rough cutter could pull on the vehicle and cause loss of control or rollover.



## DANGER



### TO PREVENT INJURIES AND DEATH:

Always ensure that you operate the vehicle safely to avoid rollovers or other dangerous situations.



## WARNING



### TO PREVENT INJURIES:

Do not use the platform as a work platform. The platform **is not** designed or protected for this purpose. Using the platform as a work platform could cause serious injury or even death.



## WARNING



### TO PREVENT INJURIES AND DEATH:

Debris around hot and rotating components is a fire hazard. Ensure hot engine parts and all moving components are free of debris.



## WARNING



### TO PREVENT INJURIES AND DEATH:

Never leave a rough cutter unattended, stop the engine and remove the key to prevent unwanted starting.



## WARNING



### TO PREVENT INJURIES AND DEATH:

Do not exceed the cutting capacity of the rough cutter. Exceeding the capacity may break components of the rough cutter.



## AVERTISSEMENT



### TO PREVENT INJURIES AND DEATH:

Make sure you do all required maintenance.



## AVERTISSEMENT



### TO PREVENT INJURIES AND DEATH:

Operate at a safe speed, never exceed 5 mph (8 km/h)

# OPERATION

## CONTROL AND DISPLAY



### WARNING



#### TO PREVENT INJURIES AND DEATH:

Read the towing vehicle operator's manual carefully. Familiarize yourself with the controls and how to properly operate the attachment. Know how to stop the attachment and controls quickly.

## MEANING OF SYMBOLS ON THE CONTROL BOX

### Item 1: Energy symbol

This identifies the emergency stop items on the control box.

### Item 2: Clutch symbol

This symbol is to locate the elements related to the electric clutch of the rough cutter blades.

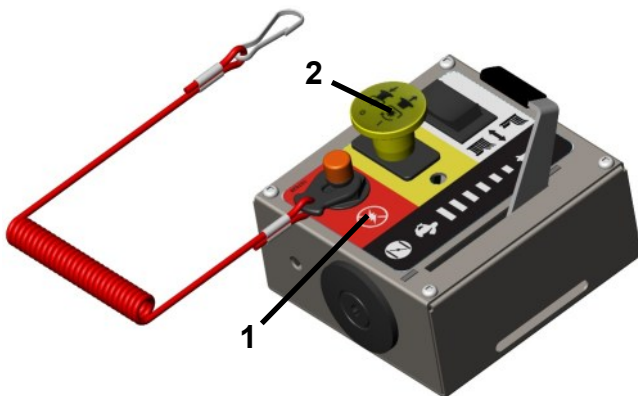

## EXPLANATION OF DIFFERENT CONTROL ELEMENTS



### WARNING



#### TO PREVENT INJURIES:

It is a possibility that in certain cases, the safety lanyard may be too long and will not function properly due to where the control box is installed on the vehicle and where the lanyard is attached to the operator.

**It is the operator's responsibility** to make sure that the lanyard is well installed so the equipment stops when the operator leaves the seat.

**If required:** Shorten the lanyard making sure it retains its original and adequate resistance.

### Item 1: Ignition switch.

Using the key: Allows to start the engine or you may turn the key to the accessory setting to activate the controls without starting the engine. The light (item 7) is on when the key is turned to the accessory or start setting.

Always remove the key when the equipment is left without surveillance.

### Item 2: Throttle lever

Push towards the front to increase engine speed, push completely to the end to "start" / choke.

### Item 3: Emergency switch

Push to stop equipment quickly.

### Item 4: Safety lanyard:

Links the operator to the control box. If the operator leaves the driver's seat without stopping the equipment, the equipment will stop (the cable will disconnect itself from the control box).

### Item 5: Engagement switch

Pull to engage, push to disengage the electric clutch. The light (item 8) is on when equipment is engaged.

### Item 6: Height adjustment switch.

Allows to adjust the cutting height.

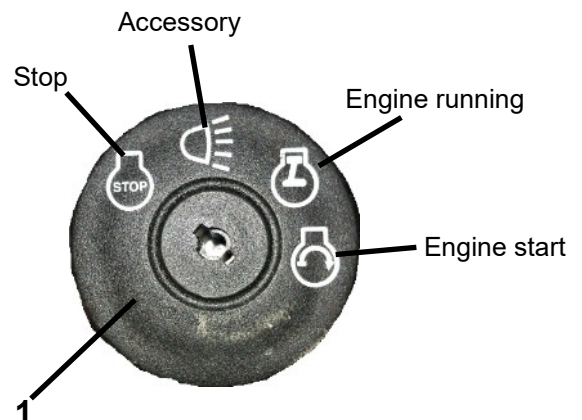
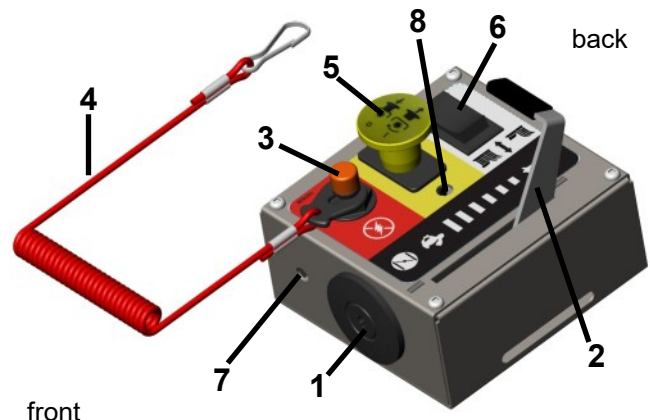

# OPERATION

## PRE-OPERATION INSPECTIONS

To be done before each operation.



### WARNING



#### TO PREVENT INJURIES:

Clear area to be cut of debris and other unforeseen removable objects before cutting. Mark any potential hazards that cannot be removed such as tree stumps, post, rocks, holes, and drop-offs with a visible flag.



### WARNING



#### TO PREVENT INJURIES:

Do not operate cutter with loose hardware. Loose hardware can result in a breakdown causing serious injury or death.



### WARNING



Loose blades can easily pierce a 1/4" steel plate. Loose blades can also be thrown up to 300 feet.

#### TO PREVENT SERIOUS INJURIES, DEATH AND MATERIAL DAMAGE:

**Periodically (and after a full day) disengage ELECTRIC CLUTCH**, shut down engine, remove key, and :

- **Check** for foreign objects wrapped around the rotor shaft.
- Block cutter deck up before removing objects.
- Frequently **inspect** cutter for any sign of wear or loose bolts and nuts (especially the stump jumper and the blade bolts).
- **Tighten** as indicated in the Torque specification table.
- Make sure all guards are in place at all times.

Perform the following inspections, ensuring that:

- The accessory attached to the vehicle parked on a solid, flat surface. The vehicle must be stationary with the parking brake engaged.
- Ensure that the rough cutter is disengaged, and that all moving components are completely stopped.
- The spark plugs wires of the engine of the brush cutter is disconnected and secured to avoid contact.
- When working under the mower deck, remove the spark plugs and disengage the belt from the engine pulley

## INSPECT THE VEHICLE:

Vehicle must respect the maintenance specifications as per the owner's manual.

Inspect vehicle safety equipment to make sure it is installed and in good working condition.

## INSPECT THE ENGINE:

See the engine manufacturer's recommendations for the type and amount of oil and fuel used.

The engine must be level to check and fill with oil accurately. .

- **Check the oil, oil and fuel levels.**
- Check all electrical connections to ensure there is no buildup of debris.

If the rough cutter is not level, see the section "ADJUSTMENTS" for leveling the brush cutter.

## INSPECT TIRE PRESSURE:

Check and adjust the tire pressure to the maximum pressure indicated on the accessory tire. The tire pressure should be equal on both sides.

## INSPECT THE BLADES:

For this inspection section, put the rough cutter at the highest level (see height adjustment section in the "ADJUSTMENTS" section. Install fixed supports under the rough cutter to ensure that it cannot fall.

- Make sure there is nothing underneath the accessory that should not be there.
- Check and remove foreign objects around the blades and the main axis of the blades, because this can cause vibrations and prevent the blades from pivoting.
- Check the blades for chipping, bent, broken, or worn. (Replace or sharpen the blades as needed. See "Blade Maintenance.")
- Make sure the blades rotate freely on the bolt
- Ensure that the bolt on each blade is not loose and/or broken.

## INSPECT THE ACCESSORY:

**Check the accessory frequently** for loose nuts and bolts. Tighten loose hardware as indicated in the maintenance section. If the maintenance section does not specify a torque, use the torque in the torque specification table or the maintenance section.

Validate if there is no missing guard or other broken item. Make sure that the rubber front guard is present and does not show breakage.

# OPERATION

## OPERATION INSTRUCTIONS

### PRE-OPERATION INSPECTION

Make sure to perform the pre-operation inspection before operating the equipment.

### ENGINE STARTING:



**Before starting to work**, sit on the driver's seat and always **install on yourself the emergency switch lanyard** that is linked to the control box.



**NOTE:** Do not attempt to start the unit with engagement knob pulled up in the "ENGAGED" position.

**Using the control box, follow these steps:**

- Set the throttle lever on the control box to "START" position.
- Turn key to the "ACCESSORY" setting, then to the "START" setting.
- Set throttle lever to minimum RPM.
- Allow engine to idle a few moments before engaging the blades.

### BLADE ENGAGEMENT AND DISENGAGEMENT

	<b>DANGER</b>	
<b>TO PREVENT INJURIES AND DEATH:</b> <b>Always operate from the operator's position:</b> sit in the driver's seat and make sure to always attach the emergency switch lanyard that is connected to the control box to your person. <b><u>NEVER OPERATE WITHOUT THIS LANYARD IN PLACE.</u></b>		

	<b>WARNING</b>	
<b>TO PREVENT INJURIES:</b> Disengage the clutch immediately if vibrations persist after a few seconds during start-up and at any time thereafter. Wait until the moving components come to a complete stop (20 seconds) before getting out of the vehicle to check for probable causes. Make any necessary repairs (see troubleshooting section of this manual) before proceeding.		



## WARNING



### **TO PREVENT INJURIES:**

**Start the engine, engage and disengage the electric clutch to be sure it functions normally. Make sure the emergency switch is working perfectly. Make sure all the controls are working well.**



## WARNING



### **TO PREVENT INJURIES:**

**Do not engage the blades on gravel or other debris that could be thrown by the rough cutter blades.**

### BLADES ENGAGEMENT

If you have a new belt do the belt Running in procedure (see "RUNNING IN BELT" section) If the brush cutter has never been used, follow the instructions for polishing the clutch (see section "CLUTCH BURNISHING")

1. Make sure the engine is running at idle or slightly above.
2. While engine is running at idle, engage the blades by pulling up the engagement switch.

**NOTE:** Initial start-up vibration is normal and should stop after a few revolutions.

3. Once cutter is running smoothly, slowly increase engine speed.

**IMPORTANT:** At full throttle, make sure that the accessory does not vibrate for more than 3 seconds otherwise stop immediately and go to the "TROUBLESHOOTING" section of this manual.

### BLADES DISENGAGEMENT

1. Slowly decrease throttle speed until engine idle speed is reached.
2. Then, push down the engagement switch to disengage the blades.
3. Engage vehicle park brake, shut vehicle engine off, and remove switch key. Stay on vehicle until blades are completely stopped (wait approximately 20 seconds).

# OPERATION

## **SHUTDOWN PROCEDURE**

1. Disengage the cutting blades. (see section on the engagement and disengagement of the blades in this manual)
2. Park the vehicle and rough cutter on a flat, stable surface.
3. Apply the tow vehicle's handbrake and stop the vehicle and remove the key
4. Get out of the vehicle and turn the engine key to "off" and remove the key.

**IMPORTANT:** Double-check one last time that the clutch is disengaged and that the red light on the control box is off, as the battery may drain.

## **EMERGENCY STOP**

If an emergency situation arises, press the emergency stop button on the control box. This will turn off the engine. Wait 20 seconds before exiting the vehicle to ensure the blades have completely stopped.

## **CLUTCH BURNISHING**

The burnishing procedure must be performed before the first utilisation of the accessory and after a prolonged period of inactivity. Burnishing the engaging system will ensure proper performance and will help avoid damages.

1. Make sure the blades are free of any obstruction. Start the engine.
2. Engage electric clutch.
3. Disengage electric clutch and wait for all moving parts to stop.
4. Repeat procedure (steps 2 & 3) 10 times within 30 seconds intervals to avoid overheating the clutch which may result in damage.

## **BELT RUNNING IN:**

1. Set the vehicle parking brake and chock the wheels.
2. In a safe environment, (i.e. no children or pets) allow blades to rotate and engine to idle for 5 minutes, Running in the belt for a longer life.
3. Stop rough cutter.

## **MOUNTING AND DISMOUNTING OF VEHICLE**

- See the section on mounting and dismounting the vehicle.

## **CLEANING UP A BLOCKAGE**

Follow these instructions to unlock the rotation of the blade holder or blades on the blade holder.

1. Disengage the cutting blades (see the blade engagement and disengagement section of this manual) and apply the emergency stop.
2. Park the vehicle and rough cutter on a level, stable surface.
3. Apply the towing vehicle's parking brake and stop the vehicle.
4. Turn the engine key to "off."
5. Disconnect the spark plugs wire from the rough cutter's engine and secure it to prevent contact.
6. Also remove the spark plugs.
7. Remove the drive belt (see "MAINTENANCE" section).
8. Raise the rough cutter to its highest position (see "HEIGHT ADJUSTMENT" in the "ADJUSTMENTS" section). Install fixed supports under the rough cutter to ensure that it cannot fall even if forces are applied to the rough cutter (sideways from bottom to top, downwards from front to back). **IMPORTANT:** Do not place your entire body or head under any part of the rough cutter, only your arms.
9. Remove anything blocking the blades and/or the blade holder.

# OPERATION

## CUTTING OPERATION



### WARNING



#### **TO PREVENT INJURIES:**

Do not use cutter to lift or carry objects; to pull fence posts, stumps or other objects; or to tow other equipment. Doing so can damage the cutter, cause serious injury or death.



### CAUTION



#### **TO PREVENT INJURIES:**

Do not exceed rated cutting capacity of your cutter (see « **INTENDED USE** » section) .



### DANGER



#### **TO PREVENT INJURIES AND DEATH:**

**Always operate from the operator's seat:** Sit in the driver's seat and always attach the emergency switch lanyard to the control box.

**NEVER OPERATE WITHOUT THIS LANYARD.**

## START CUTTING

- Adjust the cutting height using the adjustment switch on the control box. (See the "ADJUSTMENTS" section for more details.).
  - \* Dense areas should be cut in two passes.  
**Tip:** For brush and small trees provided, a lower fit gives a better result.
- Adjust the cutting deck parallelism with the ground (see "ADJUSTMENTS" section)
- Recheck the attachment of the rough cutter to the vehicle.
- Go to the operator's station and put on the safety lanyard.
- Still following the engine start instructions on the previous page, start the rough cutter engine and set to maximum throttle.
- Engage the blades of the rough cutter according to the instructions in the "OPERATION" section: "ENGAGEMENT OF THE BLADES".
- Start mowing at a slow travel speed.

## STOP CUTTING:

- See "BLADES DISENGAGEMENT" and "SHUTDOWN PROCEDURE" section.

## IMPORTANT DURING THE OPERATION:

- Do not operate the equipment in reverse.
- **Periodically, disengage**, turn off the accessory engine and vehicle, remove the key & check if any objects are wrapped around the blade axis. Lift and lock the accessory before removing objects. (see section "PRE-OPERATION INSPECTIONS" for the complete procedure)
- **Check the accessory frequently** for loose nuts and bolts. Tighten loose hardware as indicated in the "MAINTENANCE" section. If the maintenance section does not specify a torque, use the torque in the torque specification table or the maintenance section.

## SUGGESTED CUTTING PRACTICES:

**Keep the engine running at full throttle.**

- Low throttle will cause a poor, uneven cut and cause the blades to rotate backward too easily.
- Full throttle will ensure the best cutting performance and maximum material ejection.

## After the first 50 feet of cutting:

- Stop traveling and disengage the electric clutch.
- Check cutter levelness and cutting height to make certain it is adjusted properly.

## Optimum ground speed:

- It depends on density of material being cut and terrain.
- The rough cutter should be started with tow vehicle at low speed and increased only as safe mowing conditions permit. **Cutting speed should not exceed 5 mph (8 km/h).**
- Optimum ground speed may vary between **2 to 5 mph** (3 to 8km/h) to allow the cutter to make a smooth cut without lugging the engine down.

Cutting conditions and the types of grass or brush will vary from place to place. You may find when cutting dense areas that the pressure of the wheel tracks may cause the grass to be pushed down and not effectively mowed. If this happens you may want to mow the area twice. Once with the cutter raised and the second cutting at the desired height. **The second cutting should be at a right angle from the previous for best results.**

Reducing the travel speed will help cut dense growth. This allows the blades the time necessary to make its initial cut, and regain momentum to continue cutting and discharging debris properly. The engine may stall if you are mowing too fast!

Do not attempt to cut areas that the tow vehicle cannot maneuver through and/or slopes that you do not feel comfortable riding.

# OPERATION

For best results, in wet or rainy conditions, allow the wet grass to dry. The wet grass will clump together and collect under the rough cutter platform, creating poor discharge and premature wear. More power will also be required.

## SUGGESTED "A" CUTTING PRACTICES FOR SMALL TREES:

One method is to crush the small tree with the vehicle to prepare it to be cut by the rough cutter

To do this, the rough cutter must be behind the vehicle.

Do this safely so that you maintain control of the vehicle at all times (all wheels on the ground at all times) and without the risk of causing damage to the vehicle. Always follow the vehicle's safety precautions and instructions.

## SUGGESTED "B" CUTTING PRACTICES FOR SMALL TREES:



### WARNING



#### **TO PREVENT INJURIES:**

When cutting small, tall trees using Method B, be sure to do so with the rough cutter in offset mode (see "TOW HITCH OFFSET" in the "ADJUSTMENTS" section), as there is a risk that the falling tree could hit you and cause injury.

This method involves using a rough cutter to lay the tree flat before cutting it down. However, you must be very careful when using this technique because, depending on the tree's position, it could fall on your head.

This technique should therefore be used with a tree no taller than 4' (1.20m) and in offset mode, as shown in the following image.

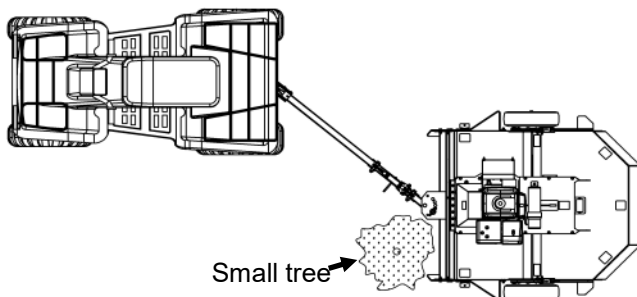

The following dangerous situation must not be created :

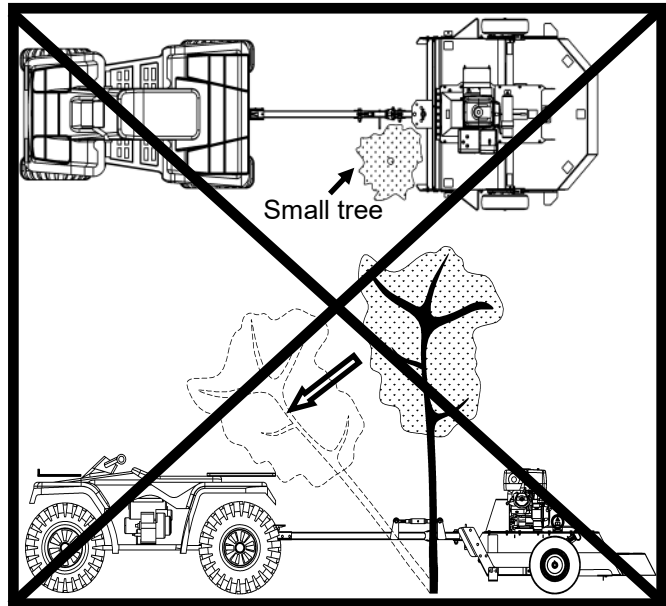

## TRANSPORTING THE ROUGH CUTTER:

- Stop the rough cutter (see shutdown procedure).
- Raise the rough cutter deck as high as possible.
- See "TRANSPORTING" section to safely transport the rough cutter.

## ADJUSTMENTS



### WARNING



**TO PREVENT INJURIES AND DEATH:**  
DISENGAGE THE BLADES BEFORE PERFORMING AN ADJUSTMENT (see blade disengagement procedure) Park on a flat, firm surface, put the parking brake on the vehicle, turn off the engine and remove the key.



### DANGER



**TO PREVENT INJURIES AND DEATH:**  
Adjust with only one person, do not allow any person within a radius of 5 meters of the vehicle and the rough cutter. If one person is in the operator's position and another on the rough cutter, the person in the operator's position can activate the clutch which can cause serious injuries or even death to the person near the rough cutter.

## ADJUSTMENT OF THE CUTTING DECK LEVEL

For best cutting results, the cutter deck should be parallel to the ground. To check parallel adjustment, measure the distance from the bottom edge of the deck in both the front and rear of the deck. This adjustment is best done while the tow vehicle and Rough Cutter are attached together. Adjust as needed using the adjustment screw of top link (item 1).

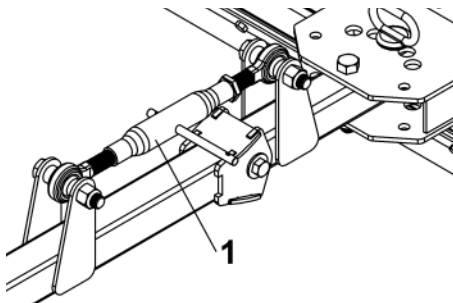

## CUTTING HEIGHT ADJUSTMENT:

There is approximately 4" of height adjustment.

Adjust the cutting height with the control button located on the control box.

Dense areas should be cut in two passes.

## TOW HITCH OFFSET:



### CAUTION



**PINCH POINT  
TO PREVENT INJURY:**  
Handle with care; do not place fingers or other body parts in the adjustment holes.

#### To offset:

1. Remove pin with hair pin 4mm (item 1).
  2. Angle hitch bar (item 2) to align with appropriate hole. Lock in place by inserting pin with hair pin 4mm desired hole.
- ⇒ Verify that the rear hitch bar of the equipment does not come into contact with the wheels of the vehicle.

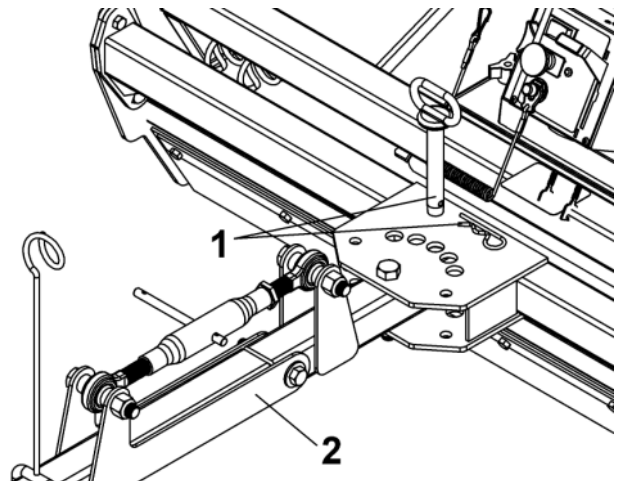

# MAINTENANCE

## SAFETY PRECAUTIONS

- Proper maintenance and a good adjustment is the key to the longevity of your equipment. Careful and systematic inspection can prevent costly repairs, maintenance or downtime.
- Never allow untrained personnel to perform maintenance on equipment.
- Always understand the procedures before performing any work.
- Use appropriate equipment and tools.
- Use a jack to support the equipment when necessary.
- Check all bolts after using the equipment for several hours to ensure they are tight.
- Check for damage to protective structures such as guards and replace damaged parts if necessary.
- Replace any worn, damaged or illegible safety decals.
- Do not modify the accessory in a way that will affect its performance.
- Refer to the engine and vehicle owner's manual for additional information.
- Always use genuine parts.

Always make sure to wear the appropriate safety equipment required (glasses, muffs, mask...).



## DANGER



### TO PREVENT INJURIES AND DEATH:

#### Before proceeding with any maintenance, assembling or dismounting always:

- Disengage the accessory.
- Ensure all moving parts have stopped before dismounting.
- Stop on a firm, level surface.
- Apply the vehicle's parking brake.
- Stop the vehicle and remove the key.
- Stop the accessory engine and remove the key from the ignition.
- Disconnect the spark plugs wires and keep it away from the spark plugs to prevent accidental starting.
- For any maintenance under the mower deck, disengage the belt from the engine pulley.



## DANGER



### TO PREVENT INJURIES:

Always secure the cutting deck in the raised position with solid supports before performing maintenance under the attachment.

### GENERAL RECOMMENDATIONS

The warranty on this rough cutter does not cover items that have been subjected to operator abuse or negligence. To receive full value from the warranty, operator must maintain unit as instructed in this manual.

Some adjustments will need to be made periodically to maintain your unit properly.

## MAINTENANCE SCHEDULE

### BEFORE EACH SEASON:

New spark plugs and clean air filter assure proper air fuel mixture and help your engine run better and last longer.

- Replace the spark plugs.
- Clean or replace the air filter.
- Check blades and belts for wear. If wear is detected, please replace.

### BEFORE EACH USE:

- Check mounting bolts to prevent costly repairs.
- Check engine oil level. Do this twice to ensure an accurate reading.
- Check condition of air filter and clean or replace if necessary.
- Check blade operation.
- Check for loose fasteners, if so, please tighten.
- **Verify and adjust the pressure** of the tires of the rough cutter. The tire pressure must be even on both sides. Do not exceed the maximum inflation pressure shown on the tire sidewall.

### ENGINE MAINTENANCE

Maintain the engine according to the instructions in the engine owner's manual.

# MAINTENANCE

## BLADES MAINTENANCE

It is recommended that you reach an authorized dealer/qualified service technician to service and/or replace your rough cutter blades.



### DANGER



#### TO AVOID SERIOUS INJURIES: OR DEATH

A locknut that has been removed can lose its thread locking properties. Reusing a used locknut can result in a thrown blade. Always use a new locknut when installing blades.



### WARNING



#### TO PREVENT INJURIES:

Do not operate cutter with blades that are bent, out of balance, excessively worn, excessively nicked, or with blade bolts that are excessively worn. **Such blades can break loose from the cutter at high speeds** causing serious injury or death.



### CAUTION



#### DO NOT HANDLE CUTTER BLADES WITH BARE HANDS.

Careless or improper handling may result in serious injury. Always use sturdy gloves

To access the blade bolts, to remove or tighten, remove the guard (item 1) and the guard (item 2) by removing the bolts (item 3) and lock washers (item 4). The socket will block the rotation of the blade holder by leaning on the frame of the rough cutter.

**ALWAYS** put the guard back in place before operating.

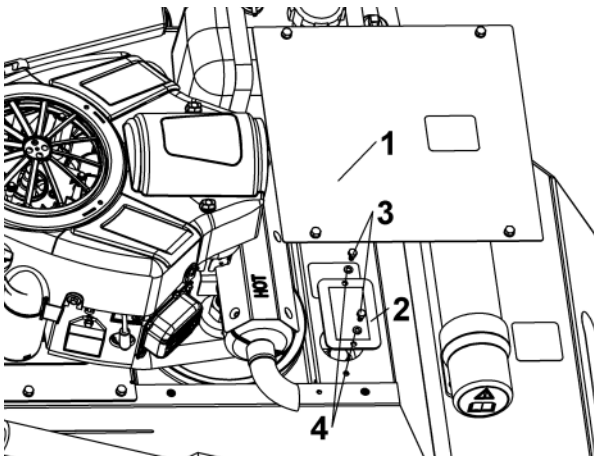

## Installation/replacement of the blades

Carefully check the edges of the blades in relation to the rotation of the jumper to ensure that they are correctly positioned. The blades rotate clockwise.

The blades must be replaced in opposite pairs. Failure to replace both blades will cause imbalance that could contribute to premature wear and bearing breakage and/or structural cracks and excessive vibration.

#### To install a blade:

1. Install the blade (item 1) using the cutting blade bolt (item 2) (make sure to align the key paths (item A with item B)

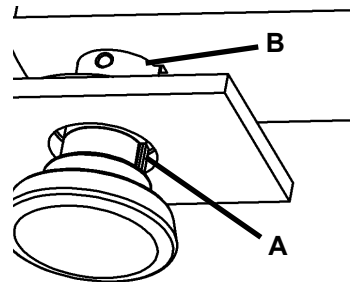

2. Place the shim (item 3) between the blade and the blade holder (item 4).

**IMPORTANT:** Ensure that the shim (item 3) is not stuck under the bolt key, which could prevent the bolt from being located in the correct position.

3. Secure the assembly with the washer (item 5) and a **new nut** (item 6). Use a 1-11/16" socket and a tightening torque of **450 lbs/ft.** Then, insert the cotter pin (item 7).
4. After installation, the blade should rotate freely. Otherwise, this will cause vibrations that can lead to breakage or injury.
5. Put back the guard.

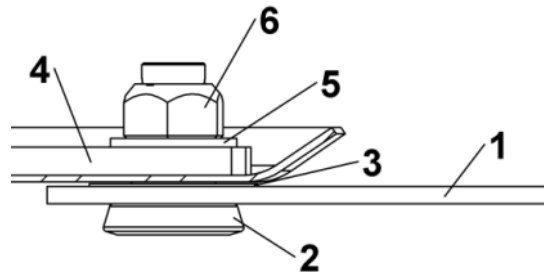

**IMPORTANT:** Examine blade bolts and washer for excessive wear and replace if worn. Always use a new locknut.

#### To remove a blade:

- Insert a socket into the opening on top of the rough cutter that provides access to the blade bolt.
- Then, using a tool, unscrew the nut.

# MAINTENANCE

## Sharpening blades:

The blades can be sharpened with an electric grinder. **DO NOT ATTEMPT TO** sharpen while on the rough cutter.

Both blades should be sharpened at the same angle as the original cutting edge and must be replaced or re-sharpened at the same time to maintain proper balance. When sharpening blades:

1. Do not remove more material than necessary.
2. Do not heat and pound out a cutting edge.
3. Do not grind blades to a razor edge. Leave a blunt cutting edge approximately 1/16" thick.
4. Always grind cutting edge so end of blade remains square to cutting edge and not rounded.
5. Do not sharpen back side of blade.
6. Both blades should weigh the same after sharpening  $\pm 1 \frac{1}{2}$  oz ( $\pm 0.1$  lbs).

## BELT REPLACEMENT



### CAUTION



#### **RISK OF BURNS:**

Make sure not to touch the engine muffler for 30 minutes after the engine has stopped.

Use a V belt MXV5-500 (#102153) as a replacement belt.

1. Remove the belt guard (item 1) by removing the four hex. bolts 5/16" n.c. x 3/4" (item 2) and four lock washer 5/16" (item 3);
2. Raise the tensioner (item 4) to remove the tension on the belt (item 5);
3. Remove the old belt and install the new one;
4. Reapply the tension on the belt by lowering the tensioner;
5. Make sure the flat idler tensioner pulley is properly aligned on the pulley.
6. Reinstall the belt guard with four hex bolts 5/16" n.c. x 3/4" (item 2) and four lock washer 5/16" (item 3).

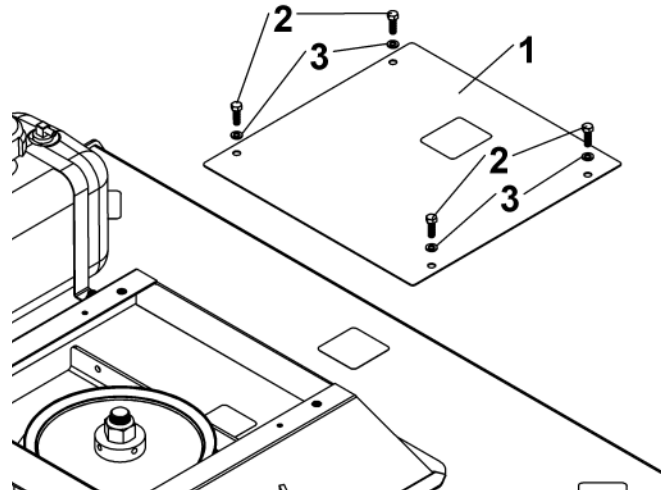

## BELT TENSION ADJUSTMENT

If the installed belt becomes too stretched, it is possible to adjust the tension of the spring (item 6) by tightening the eye bolt (item 7) until the spring is the correct length.

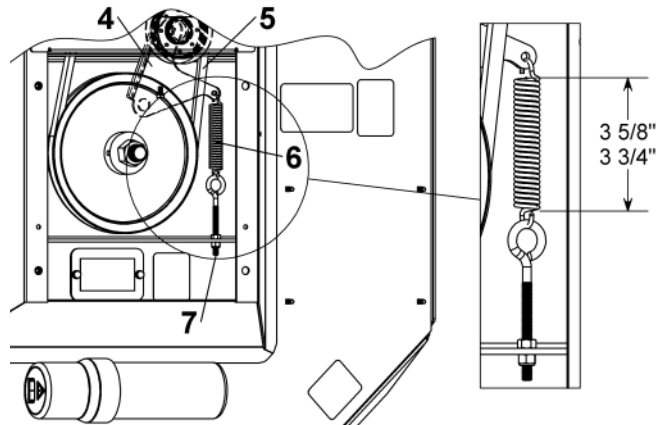

# MAINTENANCE

## IMPORTANT TIGHTENING TORQUES:

In order to prevent costly repairs, check mounting bolts at frequent intervals for proper tightness. Make sure your attachment is in safe working condition.

Before each use, verify the tightening torques mentioned below.

## IMPORTANT:

Unless otherwise specified, torque all bolts according to torque specification table (see table of contents). Refer to parts breakdown section for part identification.

## Engine base:

Place the extra strong thread locker on the ten hex. bolts 5/16" n.c. x 3/4" GR5 (**item A & B**) and tighten them with the following torque:

- 20.5 lbs-ft (246 lbs-in)

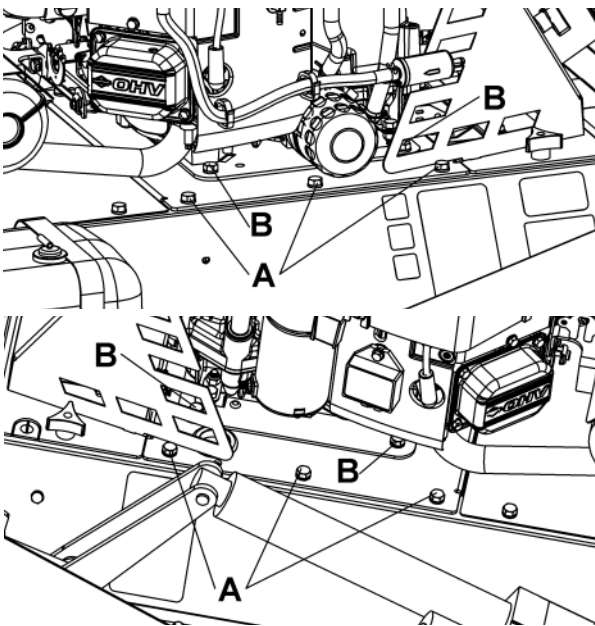

## Electric clutch:

Tighten the hex. bolt 7/16" n.f. x 1 1/2" GR5 (**item C**) with the torque below:

- 45 lbs-ft

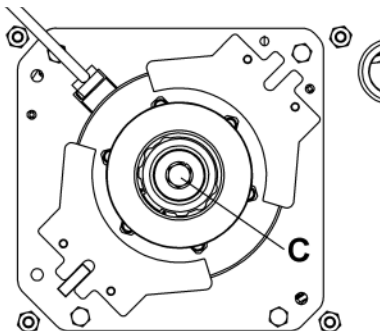

## Hub assembly :

Place the extra strong thread locker on the hex. bolts 1/2" n.f. x 2" GR8 (**item D**) of the hub and tighten the four nylon insert lock nuts with the following torque:

- 120 lbs-ft

## Pulley and blades assembly:

Place the extra strong thread locker on the threads of the hub and tighten them with the two nylon insert lock nut 1" n.c. (**item E**) using the following torque:

- 325-350 lbs-ft

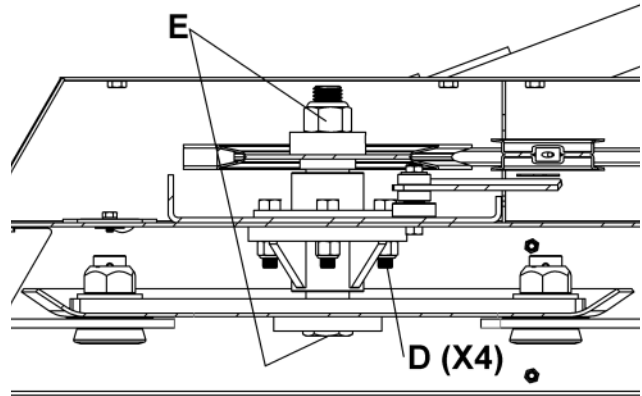

## WARNING



### TO PREVENT INJURIES:

Do not operate cutter with loose hardware. Loose hardware can result in a breakdown causing serious injury or death.

## TRANSPORTATION

### TO TRANSPORT THE ROUGH CUTTER:

- Always **disengage ELECTRIC CLUTCH** and shut down engine, before raising cutter to transport position.
- Raise cutter to transport position.
- **ALWAYS CLOSE THE ENGINE FUEL INLET VALVE.**

When transporting the equipment without towing it behind a vehicle, disconnect the wire from the spark plugs and keep away from spark plugs to prevent accidental starting.

### **IMPORTANT:**

- Reduce vehicle ground speed when turning and leave enough clearance so cutter does not contact obstacles such as buildings, trees, or fences.
- When traveling on roadways, transport in such a way that faster moving vehicles may pass you safely.
- Reduce speed when traveling over rough or hilly terrain.
- Always look down and behind, before and while driving backwards.
  - ⇒ Verify that the rear hitch bar of the equipment does not come into contact with the wheels of the vehicle.



## DANGER



### **TO PREVENT INJURIES:**

Do not operate and/or travel across **steep inclines** where a vehicle can rollover resulting in serious injury or death.

Consult your vehicle's manual for acceptable inclines the vehicle is capable of traveling across.

Never operate on slopes of more than **15 degrees**.



## WARNING



### **TO PREVENT INJURIES:**

When traveling on public roads, use accessory lights, SMV sign, clean reflectors, and other adequate devices to warn operators in other vehicles of your presence. Always comply with all federal, state, and local laws.

## DISMOUNTING AND STORAGE

### DISMOUNTING:

1. Disengage cutter blades.
2. Select a level surface, set the parking brake, stop the engine and remove the ignition key to prevent accidental starting.
3. Stop the rough cutter engine and remove the key to prevent unwanted starting.
4. Remove the control box from the vehicle and place it on the battery guard of the equipment.
4. Detach the equipment from the vehicle by removing the rear ball hitch.

### LONG TERM STORAGE

1. Clean off any dirt and grease that may have accumulated on the cutter and moving parts. Scrape off compacted dirt from the bottom of deck and then wash surface thoroughly with a garden hose. A coating of oil may also be applied to the lower deck area to minimize oxidation.
2. Close the fuel inlet valve, start the engine and wait until it runs out of fuel.
3. Check blades and blade bolts for wear and replace if necessary. See "Cutter Blade Maintenance" section.
4. Inspect cutter for loose, damaged, or worn parts and adjust or replace as needed.
5. Repaint parts where paint is worn or scratched to prevent rust.
6. Replace all damaged or missing decals.
7. Follow instructions in the owner's manual of the engine.
8. Store cutter on a level surface in a clean, dry place. Inside storage will reduce maintenance and make for a longer cutter life.
9. Store the control box in a place protected from moisture.
10. Disconnect and remove the battery. (See safety precautions in the battery assembly section.)

# SPECIFICATIONS

Specifications	
Model number	701207
Total length	122 1/4"
Width	58 3/4"
Height	33"
Weight (approx.)	585 lbs
Power	20 cv
Weight on the hitch ball (approx.)	60 lbs

## CENTER OF MASS

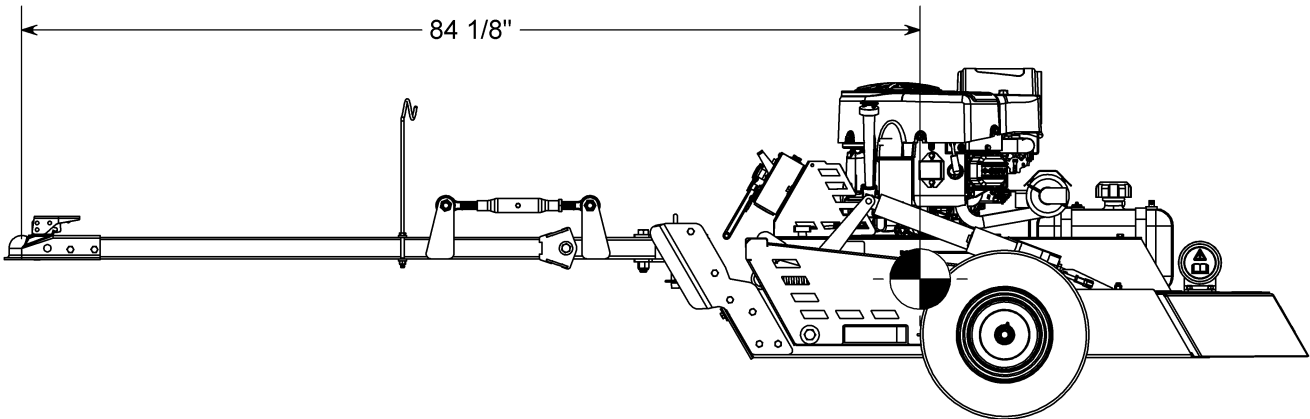

# TROUBLESHOOTING

\* Please refer to parts breakdown section for parts identification.



## CAUTION



**IF PROBLEMS PERSIST, REFER TO A QUALIFIED MECHANIC TO INSPECT EQUIPMENT. NEVER ATTEMPT ANY ADJUSTMENT WHICH YOU ARE NOT ASSURED OF GETTING THE PROPER RESULTS, THIS COULD RESULT IN FURTHER DAMAGES OR PROBLEMS.**

PROBLEMS	POSSIBLE CAUSES	CORRECTIVE ACTIONS
Excessive vibration	Blades are not free to turn	Check the installation (see the section on blades maintenance)
	Loosening of the blades	Tighten the blade bolts
	Bent blade holder	Replace the blade holder
	Broken Blade	Replace the blade
	Blades have unequal weight	Replace the 2 blades
Breakage of the blades	Solid object strike	Avoid hitting solid objects with the blades
Bent blade holder	Solid object strike	Avoid hitting solid objects and replace the blade holder
Blade bolt hole wear	Loosening of the blade hardware	Replace the blades and bolts as well as the blade holder if they are worn.
Loosening of the blade bolts	Blades not properly tightened	Tighten the hardware properly (see rough cutter blade maintenance)
	Missing threadlocker and / or lock washer	Install hardware properly (see rough cutter blade maintenance)
Unusual noises	Loose blade bolts or worn bearings or loose element	Tighten bolts, check wear items and change as needed.
	The stump jumper is twisted	Replacing the stump jumper
	Twisted deck causing the blades to hit the sides.	Straighten the deck.
Poor cutting	Failing to maintain a good engine speed.	Operate at a good pace.
	Inadequate fit.	Adjust according to owner's manual.
	The operating speed is too fast for the speed of the blades	Coordinates the operating speed with the speed of the blade.
	Blunt blades	Sharpen the blades.
Cutting leaves strips	Cut is too high, leaves wheel marks.	Reduce cutting height and operating speed
	Failing to maintain a good engine speed.	Operate at full capacity.
	Operating speed too high.	Slow down.
The unit does not cut at the level.	Poorly adjusted deck level.	Leveling the deck.
	Tire is deflated.	Check the pressure of all the tires, make sure it is equal. See the maximum pressure on the tires.
	Blades are improperly installed.	Without the engine running, make sure the blades are installed identically.

# TROUBLESHOOTING

\* Please refer to parts breakdown section for parts identification.

PROBLEMS	POSSIBLE CAUSES	CORRECTIVE ACTIONS
<b>The accessory does not rotate.</b>	The belt may slip, be damaged or severed.	Check the belt and replace the damaged belt.
<b>The belt breaks, frays, burns, or is worn in a specific location.</b>	The accessory was engaged while it was stuck.	Make sure the blades are not jammed before activating the clutch.
	There is a lack of tension on the belt.	Replace the tension spring if it has lost its effectiveness.
<b>The belt shows premature wear.</b>	Not the original belt.	Always use the original belts.
	Worn belt, which can cause loosening.	Inspect the belt. Replace if required.
	Imperfections in the pulleys.	Check the pulleys for damage. The pulleys should be rust-free. Sand or replace pulleys.
	Interference.	Make sure the belt does not come into contact with other parts, bolts, guides when engaged.
<b>The accessory sinks into the ground.</b>	The ground is too soft.	Do not operate in ground that is too soft or soggy.
<b>The engine does not start.</b>	The emergency stop switch is pressed.	The emergency switch button must be raised before starting the accessory engine.
	The emergency stop switch is defective	Replace the emergency switch.
	Lack of electrical current (A).	Turn the key to the "OFF" position, check the battery and all other electrical connections, and inspect the spark plugs and wire.
	The electromagnetic clutch is activated	Disable the electromagnetic clutch
	Other reasons.	See engine manual. Contact the engine manufacturer or a qualified representative mechanic.
<b>Electric clutch slides</b>	The power supply is not sufficient.	The vehicle's battery must be recharged or changed.
	The power supply is broken.	Some wires are damaged and need to be replaced.
	The clutch plates are contaminated	Clean the clutch plates of all dirt with a brake cleaner.
<b>The electric clutch is noisy or vibrates a lot</b>	The bolt securing the clutch is not sufficiently tightened.	Replace defective parts.
	Parts of the clutch are damaged.	Replace defective parts.

# TROUBLESHOOTING

\* Please refer to parts breakdown section for parts identification.

PROBLEMS	POSSIBLE CAUSES	CORRECTIVE ACTIONS
<b>Electric clutch not working</b>	The ignition switch is in the OFF position.	Turn the ignition switch to the ACCESSORY position.
	A wire is broken or disconnected.	Check electrical connections.
	The emergency stop switch is pressed.	The emergency stop switch button must be raised before starting the accessory engine.
	The emergency stop switch is defective	Replace the emergency stop switch.
	The switch does not work.	Replace the switch.
	The relay or circuit breaker is defective.	Replace the defective part.
	The clutch is damaged	Replace the clutch
<b>The tire doesn't keep its air</b>	Perforated Tire	If loses air very slowly (small leak):  Inflate and drive at (9 mph (15 km/h)) for a few minutes. The tires are filled with tire sealant and must rotate for the sealant to block the leak.
		If loses air very quickly (big leak): replace the tire
<b>The rough cutter leaps excessively when towing.</b>	Tire pressure too high.	Reduce the pressure in the tires.
	Moving too fast	Towing more slowly.
<b>Engine not working well.</b>	The fuel is stale.	Replace the fuel, clean the fuel filter and the fuel line. Use a suitable fuel stabilizer.
	Lack of power (A)	Check the spark plugs and the orifice.

# TROUBLESHOOTING

\* Please refer to parts breakdown section for parts identification.

PROBLEM	POSSIBLE CAUSES	CORRECTIVE ACTION
<b>Actuators don't hold charge.</b>	New actuators.	It may be necessary to 100-200 lifts before the actuators hold their charge due to internal lubrication.
<b>Actuators run backwards</b>	Switch wires reversed.	Recheck wiring.
	Battery wires reversed.	Recheck wiring.
<b>Actuators (or one) will not operate</b>	Ignition switch is at OFF position.	Turn ignition switch at ON position.
	Broken wires or bad connection.	Check for poor connections.
	Control switch is inoperative.	Replace control switch.
	Relay or breaker is damaged.	Replace the relay or breaker.
	Actuators are damaged.	Replace or repair actuators.
<b>Actuators run but with insufficient power or line speed.</b>	Weak battery.	Recharge or replace battery. Check charging system.
	Poor battery connection.	Check battery terminals for corrosion. Clean when required.
	Actuators are damaged.	Replace or repair actuators.

HOW TO KNOW	POINTS TO CHECK
<b>Actuators are damaged.</b>	The ultimate test is to connect the actuators directly to the battery and reverse the wires to test both directions. If the actuators don't work, they are damaged.
<b>The breaker is damaged.</b>	Check the resistance with multimeter on both terminals of the breaker. If no contact, replace the breaker. (Sometimes, it could take a few minutes for the breaker to automatically reset itself).

**NOMENCLATURE ET LISTE DES PIÈCES / PARTS BREAKDOWN & PART LIST**

Débroussailluse 44" avec moteur commercial 20 CV #701207  
Rough Cutter 44" with 20 HP Commercial engine #701207

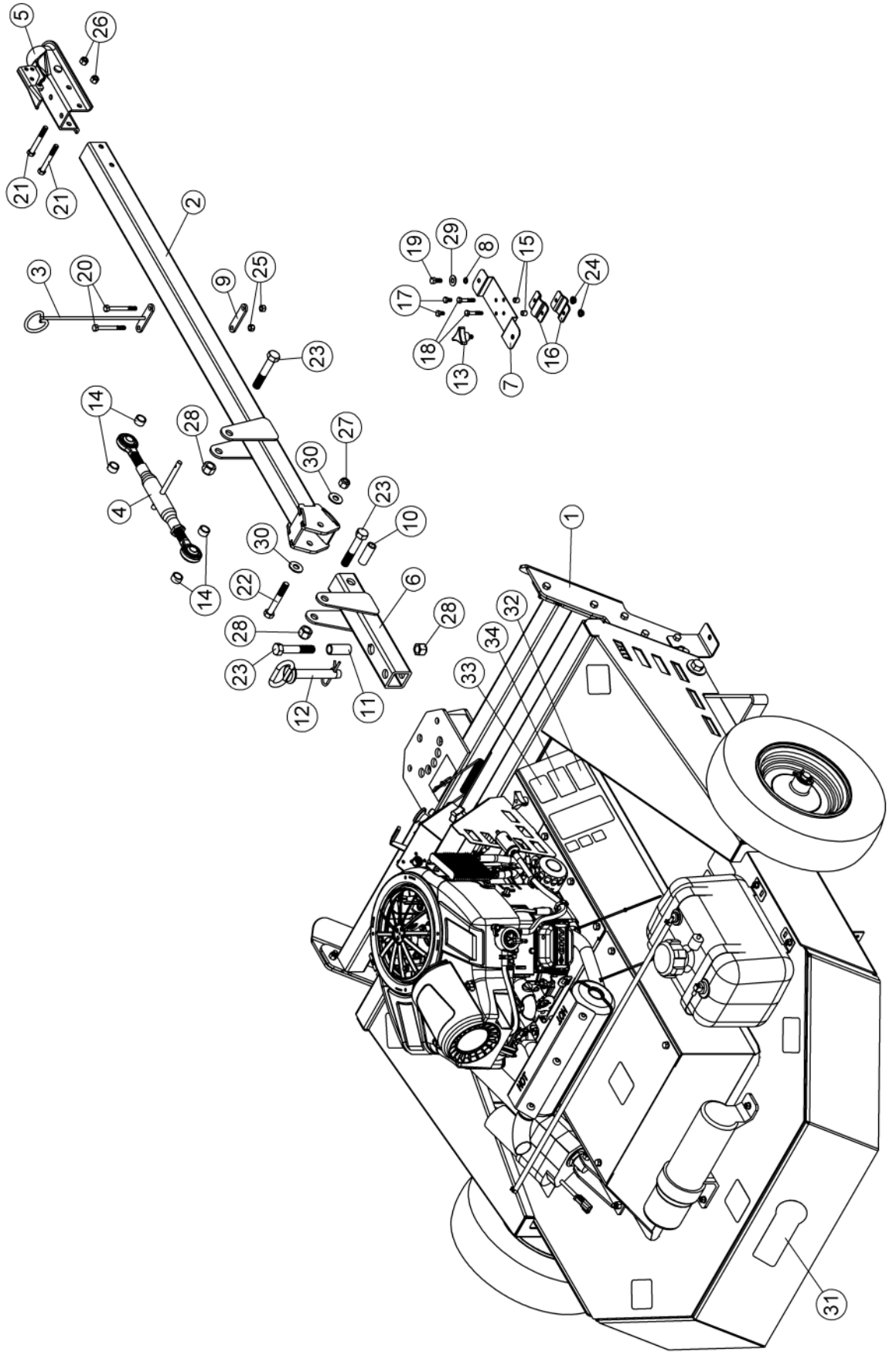

**NOMENCLATURE ET LISTE DES PIÈCES / PARTS BREAKDOWN & PART LIST**  
**Débrousailleuse 44" avec moteur commercial 20 CV #701207**  
**Rough Cutter 44" with 20 HP Commercial engine #701207**

REF.	ENGLISH DESCRIPTION	DESCRIPTION FRANÇAISE	QTY.	PART#
1	Complete rough cutter 44"	Débrousailleuse complète 44"	1	501754
2	Pull bar	Barre de tire	1	111076
3	Cable holder	Support de câble	1	111370
4	Top link	Lien supérieur	1	107356
5	Hitch	Attache	1	106130
6	Rear hitch bar	Barre d'attache arrière	1	108223
7	Box support	Support de la boîte	1	108256
8	O-Ring	Anneau d'étanchéité	1	108313
9	Cable holder plate	Plaque de support de câble	1	111371
10	Sleeve	Douille	1	108559
11	Sleeve	Douille	1	108224
12	Pin with hair pin 4mm	Goupille avec goupille à ressort 4mm	1	106736
13	Knob	Bouton	1	106861
14	Sleeve	Douille	4	107486
15	Spacer .41x.27x.38"	Espaceur .41x.27x.38"	2	103368
16	Support bracket	Fixation du support	2	103068
17	Hex. bolt 1/4" n.c. x 1/2" GR5	Boulon hex. 1/4" n.c. x 1/2" GR5	2	O/L (300NC.5P_1-4x1-2)
18	Hex. bolt 1/4" n.c. x 1 1/2" GR5	Boulon hex. 1/4" n.c. x 1 1/2" GR5	2	O/L (300NC.5P_1-4x1-1-2)
19	Hex. bolt 5/16" n.c. x 3/4" GR5	Boulon hex. 5/16" n.c. x 3/4" GR5	1	O/L (300NC.5P_5-16x3-4)
20	Hex. bolt 5/16" n.c. x 3" GR5	Boulon hex. 5/16" n.c. x 3" GR5	2	O/L (300NC.5P_5-16x3)
21	Hex. bolt 3/8" n.c. x 3" GR5	Boulon hex. 3/8" n.c. x 3" GR5	2	O/L (300NC.5P_3-8x3)
22	Hex. bolt 1/2" n.c. x 3 1/2" GR5	Boulon hex. 1/2" n.c. x 3 1/2" GR5	1	O/L (300NC.5P_1-2x3-1-2)
23	Hex. bolt 5/8" n.c. x 3 1/2" GR5	Boulon hex 5/8" n.c. x 3 1/2" GR5	3	O/L (300NC.5P_5-8x3-1-2)
24	Flange nut 1/4" n.c.	Écrou à bride 1/4" n.c.	2	O/L (334NC.P_1-4)
25	Nylon Insert lock Nut 5/16" n.c. GR5	Écrou à garniture de nylon 5/16" n.c. GR5	3	O/L (335NC.P_5-16)
26	Nylon Insert Lock Nut 3/8" n.c.	Écrou à garniture de nylon 3/8" n.c.	2	O/L (335NC.P_3-8)
27	Nylon Insert lock Nut 1/2" n.c.	Écrou à garniture de nylon 1/2" n.c.	1	O/L (335NC.P_1-2)
28	Nylon Insert lock Nut 5/8" n.c.	Écrou à garniture de nylon 5/8" n.c.	3	O/L (335NC.P_5-8)
29	Flat washer 3/8" hole	Rondelle plate 3/8" trou	1	O/L (360.P_3-8T)
30	Flat washer 1/2" hole	Rondelle plate 1/2" trou	2	O/L (360.P_1-2T)
31	Berco decal	Décalque Berco	1	109705
32	EPA decal	Décalque EPA	1	REF.
33	Made in Canada decal	Décalque Fabriqué au Canada	1	REF.
34	Serial number	Numéro de série	1	REF.

O/L = Obtain Locally / Obtenir localement

Part numbers starting with 500XXX are not available for sale, however, separate parts are available for sale individually.

Les numéros 500xxx ne sont pas disponibles pour la vente. Au besoin, veuillez commander les numéros de pièces séparément.

**NOMENCLATURE ET LISTE DES PIÈCES / PARTS BREAKDOWN & PART LIST**  
**Débrousailluse complète 44" #501754**  
**Complete rough cutter 44" #501754**

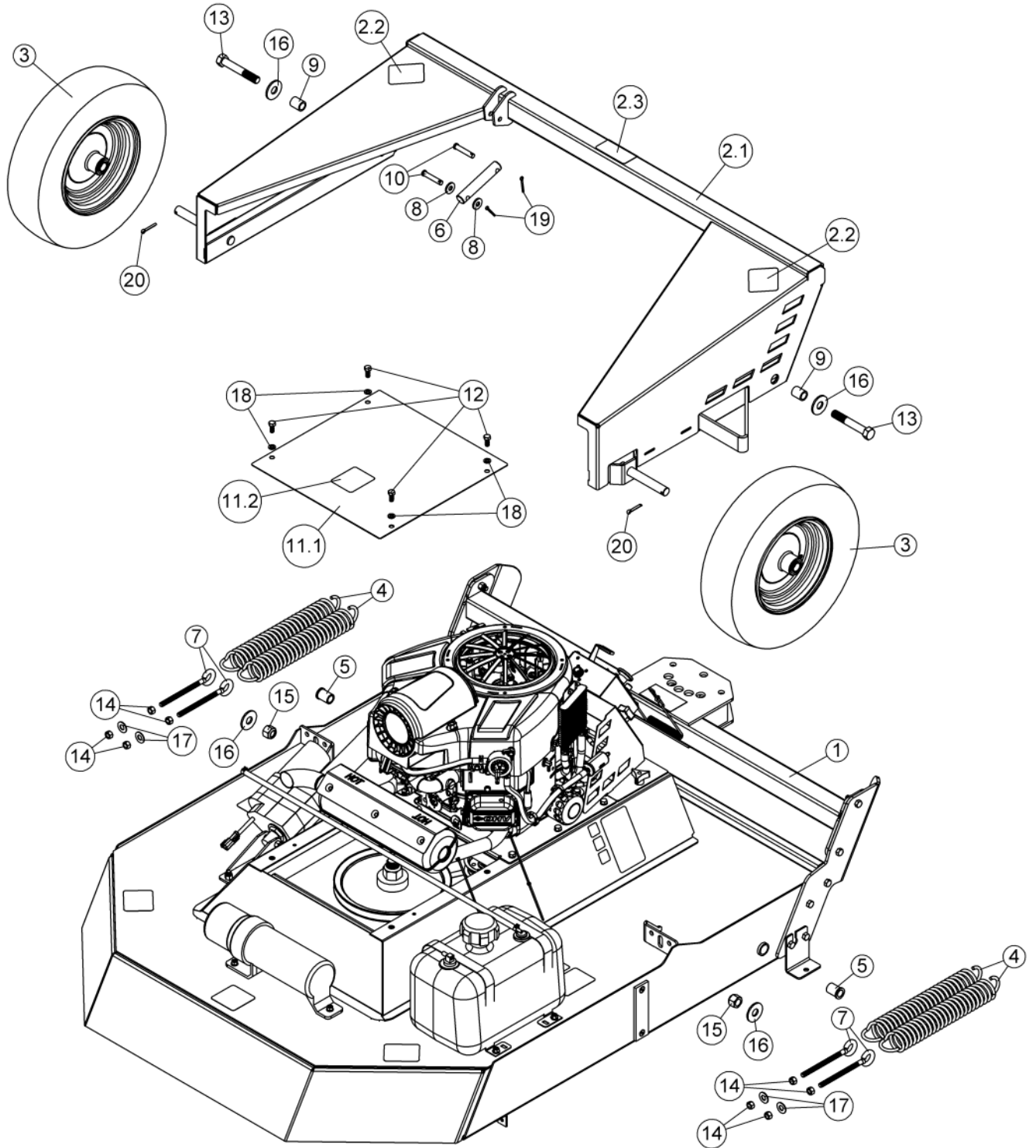

**NOMENCLATURE ET LISTE DES PIÈCES / PARTS BREAKDOWN & PART LIST**  
**Débrousailluse complète 44" #501754**  
**Complete rough cutter 44" #501754**

REF.	ENGLISH DESCRIPTION	DESCRIPTION FRANÇAISE	QTY.	PART#
1	Rough cutter with engine	Débrousailluse avec moteur	1	501753
2	Axles support #108227 w/ safety decals	Support d'axes #108227 a/ déc. de séc.	1	108292
2.1	Axles support	Support d'axes	1	108227
2.2	Mower projection decal	Decalque projection tondeuse	2	107584
2.3	Decal pinch point	Décalque point de pincement	1	105946
3	Wheel assembly	Roue assemblée	2	107275
4	Spring	Ressort	4	102918
5	Bushing	Coussinet	2	107361
6	Link	Lien	1	109801
7	Eye bolt	Boulon à oeillet	4	108237
8	Washer	Rondelle	2	106982
9	Sleeve	Douille	2	108252
10	Pin	Goupille	2	103580
11	Cover #107350 with safety decal	Couvercle #107350 a/ déc. de séc.	1	107587
11.1	Cover	Couvercle	1	107350
11.2	Decal danger belts	Decalque danger courroies	1	105128
12	Hex. bolt 5/16" n.c. x 3/4" GR5	Boulon hex. 5/16" n.c. x 3/4" GR5	4	O/L (300NC.5P_5-16x3-4)
13	Hex. bolt 5/8" n.c. x 4" GR5	Boulon hex 5/8" n.c. x 4" GR5	2	O/L (300NC.5P_5-8x4)
14	Hex. nut 3/8" n.c.	Écrou hex. 3/8" n.c.	8	O/L (330NC.P_3-8)
15	Nylon Insert lock Nut 5/8" n.c.	Écrou à garniture de nylon 5/8" n.c.	2	O/L (335NC.P_5-8)
16	Flat washer 11/16" hole	Rondelle plate 11/16" trou	4	O/L (360.P_11-16T)
17	Flat washer 7/16" hole	Rondelle plate 7/16" trou	4	O/L (360.P_7-16T)
18	Lock washer 5/16"	Rondelle de blocage 5/16"	4	O/L (362.P_5-16)
19	Cotter pin 1/8" x 1-1/4"	Goupille fendue 1/8" x 1-1/4"	2	O/L (375.P_1-8X1-1-4)
20	Cotter pin 3/16" x 1-1/2"	Goupille fendue 3/16" x 1-1/2"	2	O/L (375.P_3-16X1-1-2)

O/L = Obtain Locally / Obtenir localement

Part numbers starting with 500XXX are not available for sale, however, separate parts are available for sale individually.

Les numéros 500xxx ne sont pas disponibles pour la vente. Au besoin, veuillez commander les numéros de pièces séparément.

**NOMENCLATURE ET LISTE DES PIÈCES / PARTS BREAKDOWN & PART LIST**  
**Débroussailluse avec moteur #501753**  
**Rough cutter with engine #501753**

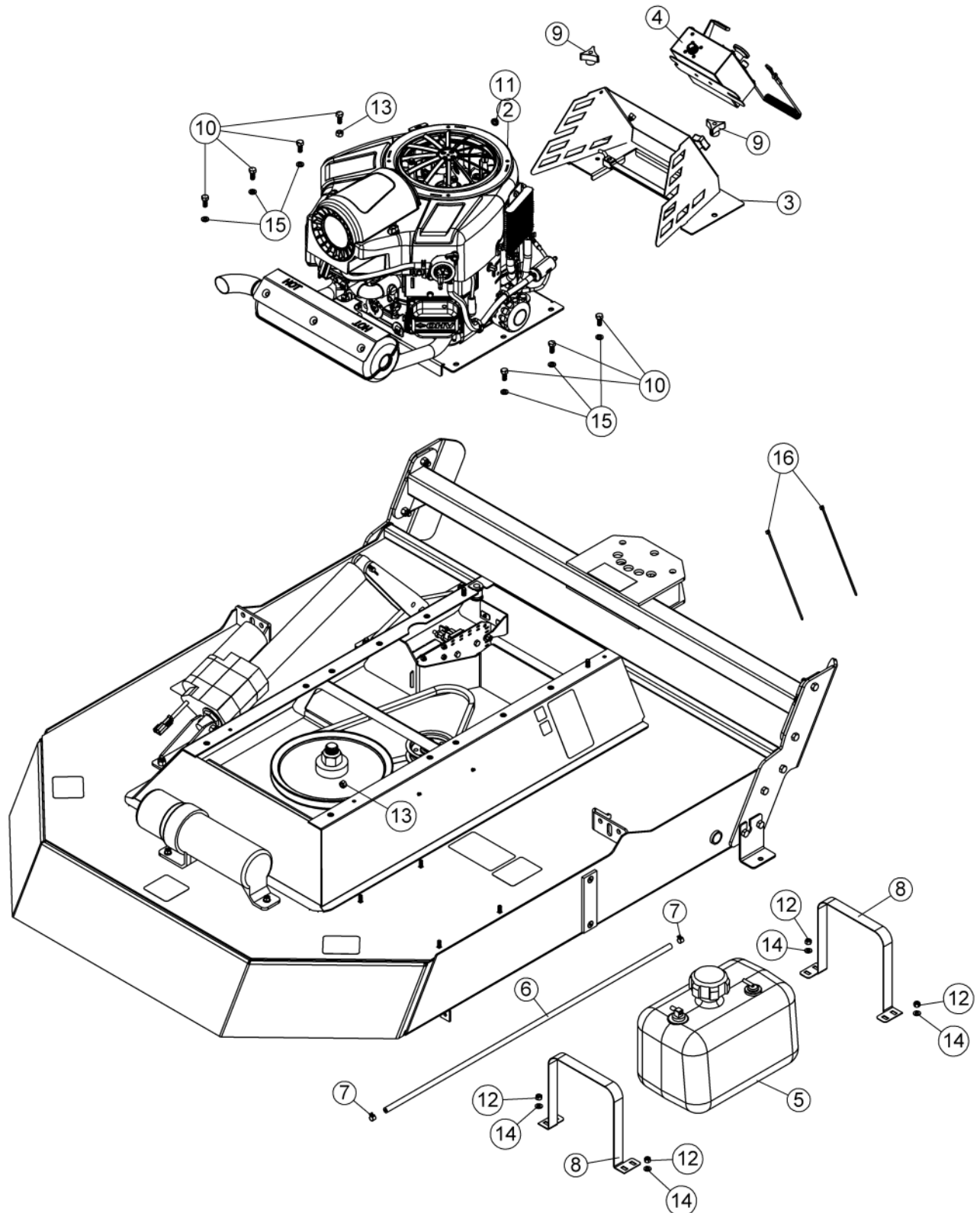

**NOMENCLATURE ET LISTE DES PIÈCES / PARTS BREAKDOWN & PART LIST**  
**Débrousailleuse avec moteur #501753**  
**Rough cutter with engine #501753**

REF.	ENGLISH DESCRIPTION	DESCRIPTION FRANÇAISE	QTY.	PART#
1	Rough cutter assembly	Débrousailleuse assemblée	1	501752
2	Briggs M40 20 HP engine with clutch	Moteur Briggs M40 20 CV avec embrayage	1	501750
3	Guard assembly	Garde assemblé	1	501019
4	Control box assembly with cable	Boîte de contrôle assemblée avec câble	1	501337
5	2.5 Gallon EPA gasoline tank	Réservoir à essence 2.5 gallon EPA	1	107264
6	Low pressure fuel hose EPA 3/16"	Tuyau à essence basse pression EPA 3/16"	1	108284
7	Spring action hose clamp for 7/16" hose	Collier de serrage à ressort pour tuyau 7/16"	2	107310
8	Fuel tank tie-down	Attache reservoir	2	108248
9	Knob	Bouton	2	103027
10	Hex. bolt 5/16" n.c. x 3/4" GR5	Boulon hex. 5/16" n.c. x 3/4" GR5	7	O/L (300NC.5P_5-16x3-4)
11	Flange nut 1/4" n.c.	Écrou à bride 1/4" n.c.	1	O/L (334NC.P_1-4)
12	Nylon Insert lock Nut 1/4" n.c.	Écrou à garniture de nylon 1/4" n.c.	4	O/L (335NC.P_1-4)
13	Nylon Insert lock Nut 5/16" n.c. GR5	Écrou à garniture de nylon 5/16" n.c. GR5	2	O/L (335NC.P_5-16)
14	Flat washer 1/4" hole	Rondelle plate 1/4" trou	4	O/L (360.P_1-4T)
15	Lock washer 5/16"	Rondelle de blocage 5/16"	6	O/L (362.P_5-16)
16	Tie wrap 8" (black), 50lbs, Weather & UV-Resistant nylon 6.6	Attache de nylon 8" (noir) ,50lbs, Weather & UV-Resistant nylon 6.6	2	O/L (426-8)

O/L = Obtain Locally / Obtenir localement

Part numbers starting with 500XXX are not available for sale, however, separate parts are available for sale individually.

Les numéros 500xxx ne sont pas disponibles pour la vente. Au besoin, veuillez commander les numéros de pièces séparément.

**NOMENCLATURE ET LISTE DES PIÈCES / PARTS BREAKDOWN & PART LIST**  
**Débrousailleuse assemblée #501752**  
**Rough cutter assembly #501752**

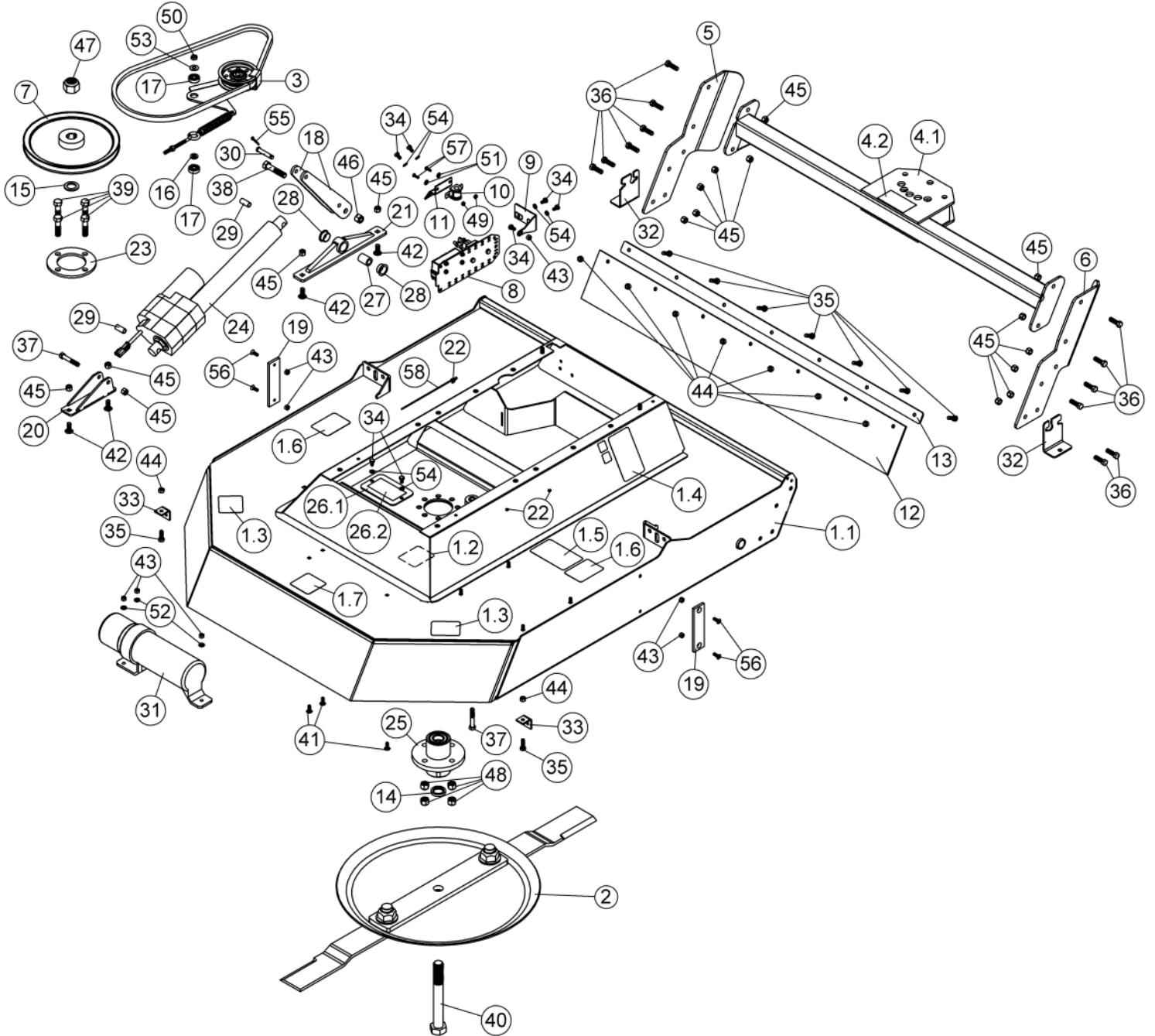

**NOMENCLATURE ET LISTE DES PIÈCES / PARTS BREAKDOWN & PART LIST**  
**Débrousailleuse assemblée #501752**  
**Rough cutter assembly #501752**

REF.	ENGLISH DESCRIPTION	DESCRIPTION FRANÇAISE	QTY.	PART#
1	Frame #111353 with safety decals	Châssis #111353 avec déc. de sécurité	1	111354
1.1	44" Frame	Châssis 44"	1	111353-E02
1.2	Decal danger belts	Decalque danger courroies	1	105128
1.3	Mower projection decal	Decalque projection tondeuse	2	107584
1.4	General message mower decal	Décalque tondeuse message général	2	107585
1.5	Decal fuel recommendations	Décalque recommandations carburant	1	108261
1.6	Decal pinch point	Décalque point de pincement	2	105946
1.7	Decal No Step	Decalque Ne pas marcher	1	108301
2	Blades assembly	Lame assemblées	1	501689
3	Bender assembly	Tendeur assemblé	1	501751
4	Front hitch bar #111077 w/ safety decal	Barre d'attache avant #111077 a/ dec. de séc.	1	111258
4.1	Front hitch bar	Barre d'attache avant	1	111077
4.2	Decal warning / crush hazard	Décalque avertissement / risque d'écrasement	1	110297
5	Left Support plate	Plaque de support gauche	1	111355
6	Right Support plate	Plaque de support droite	1	111356
7	V pulley	Poulie en V	1	104774
8	Electric board	Panneau électrique	1	108236
9	Bracket	Fixation	1	108250
10	Wire clamp	Serre-fils	1	108259
11	Bracket	Fixation	1	108260
12	Rubber guard	Garde en caoutchouc	1	107342
13	Flap fixture	Fixation de rabat	1	107343
14	Clutch spacer	Espaceur d'embrayage	1	106616
15	Special flat washer 0.13" thick.	Rondelle plate spéciale 0.13" épais.	1	106338
16	Spacer	Espaceur	1	107032
17	Ball Bearing 1614 2RS	Roulement à billes	2	107054
18	Lift lever	Levier de relevage	2	109774
19	Slide plate	Plaque de glissement	2	108258
20	Bracket	Fixation	1	109767
21	Pivot sleeve	Douille de pivot	1	109768
22	Cable Tie Mount 0.19"	Support d'attache de nylon 0.19"	3	108281

O/L = Obtain Locally / Obtenir localement

Part numbers starting with 500XXX are not available for sale, however, separate parts are available for sale individually.

Les numéros 500xxx ne sont pas disponibles pour la vente. Au besoin, veuillez commander les numéros de pièces séparément.

**NOMENCLATURE ET LISTE DES PIÈCES / PARTS BREAKDOWN & PART LIST**  
**Débrousailleuse assemblée #501752**  
**Rough cutter assembly #501752**

REF.	ENGLISH DESCRIPTION	DESCRIPTION FRANÇAISE	QTY.	PART#
23	Plate	Plaque	1	108315
24	Electric actuator	Actuateur électrique	1	108654
25	Hub assembly	Moyeu assemblé	1	109764
26	Guard #109772 with safety decal	Garde #109772 avec décalque de sécurité	1	109773
26.1	Guard	Garde	1	109772
26.2	Decal Maintenance	Décalque Maintenance	1	108556
27	Sleeve	Douille	1	109775
28	Bushing	Coussinet	2	106980
29	Sleeve	Douille	2	109800
30	Pin	Goupille	1	103580
31	Manual canister	Boîte à manuel	1	106165
32	Packaging fixture	Fixation d'emballage	2	111152
33	Packaging fixture (Square)	Fixation d'emballage (Équerre)	2	111153
34	Hex. bolt 1/4" n.c. x 1/2" GR5	Boulon hex. 1/4" n.c. x 1/2" GR5	7	O/L (300NC.5P_1-4x1-2)
35	Hex. bolt 5/16" n.c. x 1" GR5	Boulon hex. 5/16" n.c. x 1" GR5	9	O/L (300NC.5P_5-16x1)
36	Hex. bolt 3/8" n.c. x 1 1/4" GR5	Boulon hex. 3/8" n.c. x 1 1/4" GR5	12	O/L (300NC.5P_3-8x1-1-4)
37	Hex. bolt 3/8" n.c. x 2 1/4" GR5	Boulon hex. 3/8" n.c. x 2 1/4" GR5	2	O/L (300NC.5P_3-8x2-1-4)
38	Hex. bolt 1/2" n.c. x 2 1/2" GR5	Boulon hex. 1/2" n.c. x 2 1/2" GR5	1	O/L (300NC.5P_1-2x2-1-2)
39	Hex. bolt 1/2" n.f. x 2" GR8	Boulon hex 1/2" n.f. x 2" GR8	4	O/L (300NF.8P_1-2x2)
40	Hex. bolt 1" n.c. x 8" GR5	Boulon hex. 1" n.c. x 8" GR5	1	O/L (300NC.5P_1x8)
41	Carriage bolt 1/4" n.c. x 3/4" GR5	Boulon à carrosserie 1/4" n.c. x 3/4" GR5	3	O/L (320NC.5P_1-4x3-4)
42	Carriage bolt 3/8" n.c. x 1" GR5	Boulon à carrosserie 3/8" n.c. x 1" GR5	4	O/L (320NC.5P_3-8x1)
43	Nylon Insert lock Nut 1/4" n.c.	Écrou à garniture de nylon 1/4" n.c.	8	O/L (335NC.P_1-4)
44	Nylon Insert lock Nut 5/16" n.c. GR5	Écrou à garniture de nylon 5/16" n.c. GR5	9	O/L (335NC.P_5-16)
45	Nylon Insert Lock Nut 3/8" n.c.	Écrou à garniture de nylon 3/8" n.c.	17	O/L (335NC.P_3-8)
46	Nylon Insert lock Nut 1/2" n.c.	Écrou à garniture de nylon 1/2" n.c.	1	O/L (335NC.P_1-2)
47	Nylon insert lock nut 1" n.c	Écrou à garniture de nylon 1" n.c	1	O/L (335NC.P_1)
48	Nylon insert lock nut 1/2" n.f. GR8	Écrou à garniture de nylon 1/2" n.f. GR8	4	O/L (335NF.8P_1-2)
49	Nylon insert locknut #8 x 32 (thin) GR2	Écrou à garni. de nylon #8 x 32 (mince) GR2	2	O/L (336NC.P_#8x32)
50	Nylon insert lock nut 3/8" n.c. (thin)	Écrou à garniture de nylon 3/8" n.c. (mince)	1	O/L (336NC.P_3-8)

O/L = Obtain Locally / Obtenir localement

Part numbers starting with 500XXX are not available for sale, however, separate parts are available for sale individually.

Les numéros 500xxx ne sont pas disponibles pour la vente. Au besoin, veuillez commander les numéros de pièces séparément.

**NOMENCLATURE ET LISTE DES PIÈCES / PARTS BREAKDOWN & PART LIST**  
**Débrousailleuse assemblée #501752**  
**Rough cutter assembly #501752**

REF.	ENGLISH DESCRIPTION	DESCRIPTION FRANÇAISE	QTY.	PART#
51	Flat washer SAE for bolt #10 (ID 7/32" & OD 1/2")	Rondelle plate SAE pour boulon #10 (ID 7/32" & OD 1/2")	2	O/L (360.P_#10)
52	Flat washer 1/4" hole	Rondelle plate 1/4" trou	3	O/L (360.P_1-4T)
53	Flat washer 3/8" hole	Rondelle plate 3/8" trou	1	O/L (360.P_3-8T)
54	Lock washer 1/4"	Rondelle de blocage 1/4"	6	O/L (362.P_1-4)
55	Cotter pin 1/8" x 1-1/4"	Goupille fendue 1/8" x 1-1/4"	1	O/L (375.P_1-8X1-1-4)
56	Hex socket f.h. cap screw 1/4" n.c. x 3/4"	Vis à tête fraisée à 6PC 1/4" n.c. x 3/4"	4	O/L (386NC.P_1-4x3-4)
57	Machine screw Pan head no.8 x 32 x 5/8"	Vis mécanique à tête Pan no.8 x 32 x 5/8"	2	O/L (395NC.P_#8x32x5-8)
58	Tie wrap 8" (black), 50lbs, Weather & UV-Resistant nylon 6.6	Attache de nylon 8" (noir) ,50lbs, Weather & UV-Resistant nylon 6.6	1	O/L (426-8)

O/L = Obtain Locally / Obtenir localement

Part numbers starting with 500XXX are not available for sale, however, separate parts are available for sale individually.

Les numéros 500xxx ne sont pas disponibles pour la vente. Au besoin, veuillez commander les numéros de pièces séparément.

**NOMENCLATURE ET LISTE DES PIÈCES / PARTS BREAKDOWN & PART LIST**  
Tendeur assemblé #501751  
Bender assembly #501751

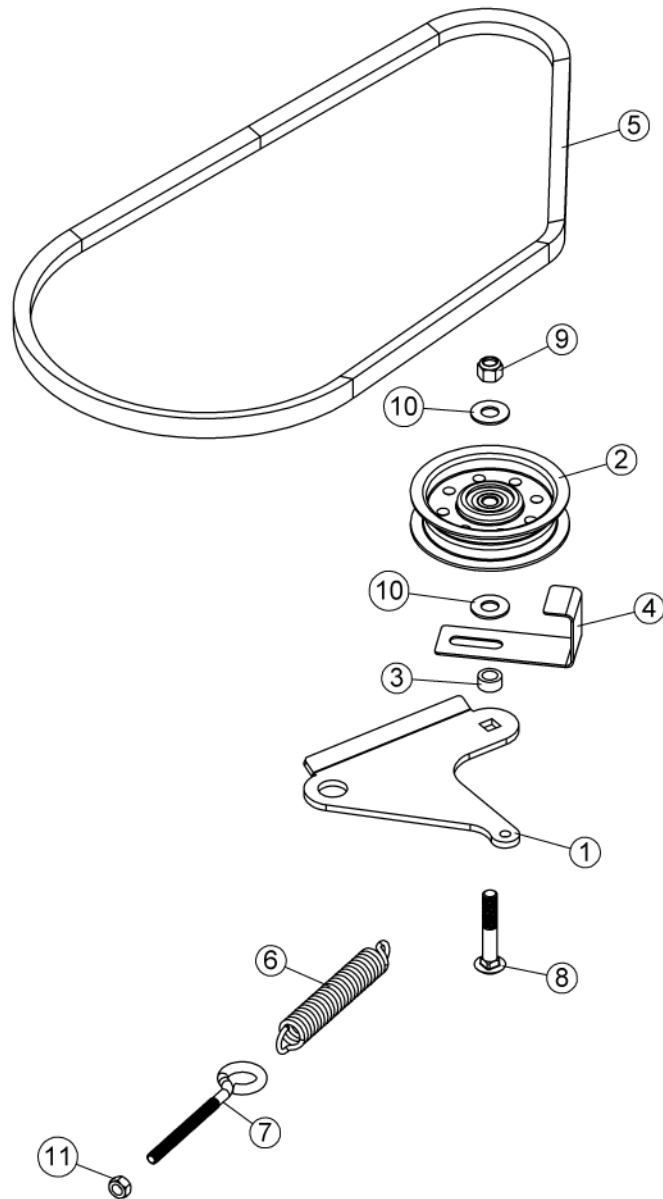

**NOMENCLATURE ET LISTE DES PIÈCES / PARTS BREAKDOWN & PART LIST**

Tendeur assemblé #501751

Bender assembly #501751

REF.	ENGLISH DESCRIPTION	DESCRIPTION FRANÇAISE	QTY.	PART#
1	Bender	Tendeur	1	107349
2	Flat pulley	Poulie plate	1	102765
3	Sleeve	Douille	1	108643
4	Belt guide	Guide-courroie	1	106878
5	V-Belt, MXV5-500	Courroie en V, MXV5-500	1	102153
6	Spring	Ressort	1	102592
7	Eye bolt	Boulon à oeillet	1	102087
8	Carriage bolt 3/8" n.c. x 2 1/4" GR5	Boulon à carrosserie 3/8" n.c. x 2 1/4" GR5	1	O/L (320NC.5P_3-8x2-1-4)
9	Nylon Insert Lock Nut 3/8" n.c.	Écrou à garniture de nylon 3/8" n.c.	1	O/L (335NC.P_3-8)
10	Flat washer 7/16" hole	Rondelle plate 7/16" trou	2	O/L (360.P_7-16T)
11	Hex. nut 5/16" n.c. GR5	Écrou hex. 5/16" n.c. GR5	1	O/L (330NC.P_5-16)

O/L = Obtain Locally / Obtenir localement

Part numbers starting with 500XXX are not available for sale, however, separate parts are available for sale individually.

Les numéros 500xxx ne sont pas disponibles pour la vente. Au besoin, veuillez commander les numéros de pièces séparément.

**NOMENCLATURE ET LISTE DES PIÈCES / PARTS BREAKDOWN & PART LIST**  
**Moteur Briggs M40 20 CV avec embrayage #501750**  
**Briggs M40 20 HP engine with clutch #501750**

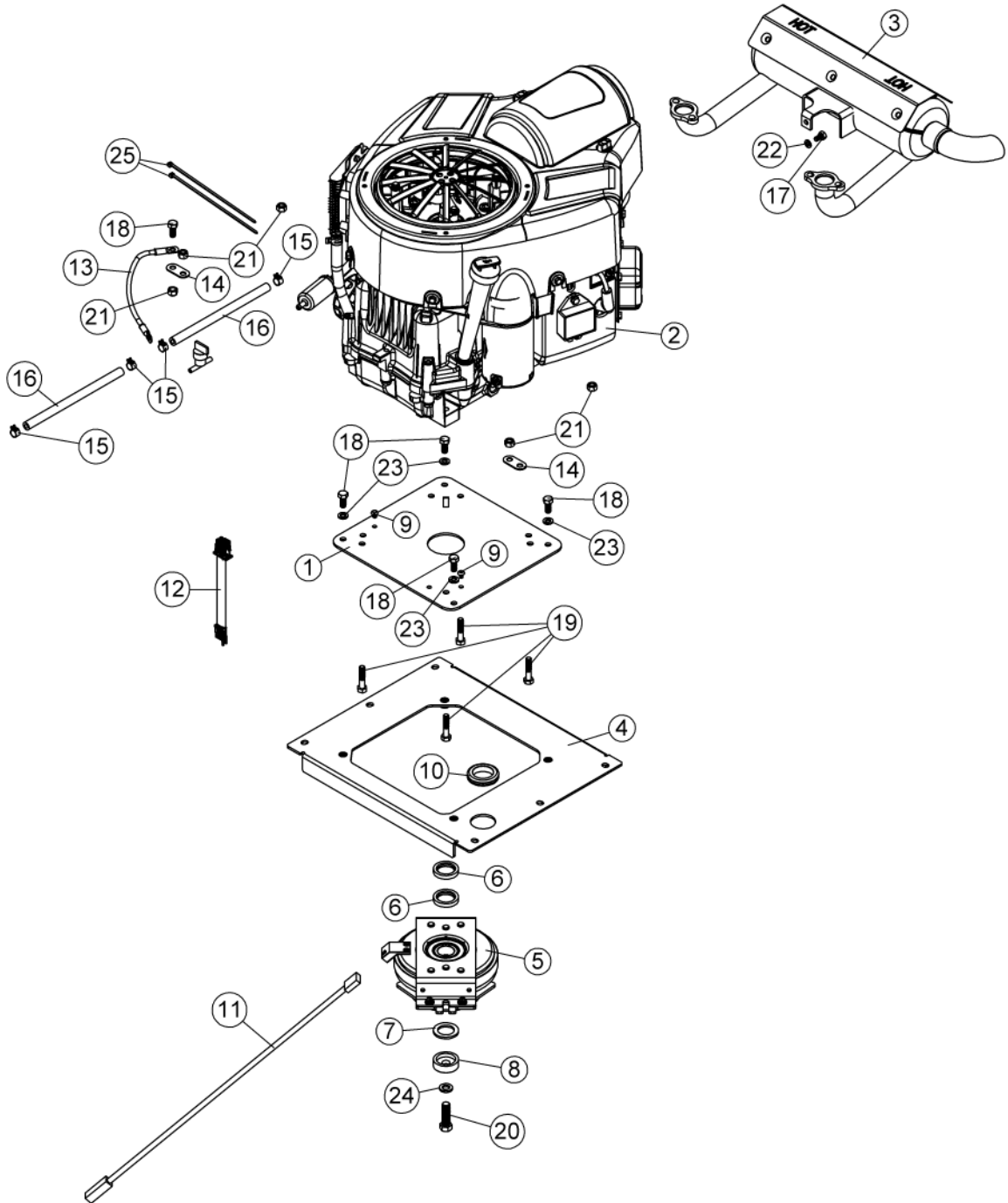

**NOMENCLATURE ET LISTE DES PIÈCES / PARTS BREAKDOWN & PART LIST**  
**Moteur Briggs M40 20 CV avec embrayage #501750**  
**Briggs M40 20 HP engine with clutch #501750**

REF.	ENGLISH DESCRIPTION	DESCRIPTION FRANÇAISE	QTY.	PART#
1	Engine support	Support de moteur	1	108262
2	Briggs M40 vertical engine 20 HP	Moteur vertical Briggs M40 20 CV	1	108221
3	Muffler assembly	Silencieux assemblé	1	108264
4	Engine base	Base du moteur	1	108263
5	Electric clutch 1" GT2.75	Embrayage électrique 1" GT2.75	1	111025
6	Clutch spacer	Espaceur d'embrayage	2	106616
7	Special flat washer 0.13" thick.	Rondelle plate spéciale 0.13" épais.	1	106338
8	Flange washer	Rondelle à bride	1	103976
9	Cable Tie Mount 0.19"	Support d'attache de nylon 0.19"	2	108281
10	Grommet	Oeillet	1	107365
11	Wire Assembly	Fil Assemblé	1	106548
12	Wire assembly	Fil assemblé	1	108291
13	Wire assembly	Fil assemblé	1	107491
14	Ground plate	Plaque de mise à terre	2	108289
15	Spring action hose clamp for 1/2" hose	Collier de serrage à ressort pour tuyau 1/2"	4	107269
16	Fuel hose EPA 1/4"	Tuyau à essence EPA 1/4"	2	107572
17	Hex. bolt 1/4" n.c. x 1/2" GR5	Boulon hex. 1/4" n.c. x 1/2" GR5	1	O/L (300NC.5P_1-4x1-2)
18	Hex. bolt 5/16" n.c. x 3/4" GR5	Boulon hex. 5/16" n.c. x 3/4" GR5	5	O/L (300NC.5P_5-16x3-4)
19	Hex. bolt 5/16" n.c. x 1 1/2"	Boulon hex. 5/16" n.c. x 1 1/2"	4	O/L (300NC.5P_5-16x1-1-2)
20	Hex. bolt 7/16" n.f. x 1 1/2" GR5	Boulon hex. 7/16" n.f. x 1 1/2" GR5	1	O/L (300NF.5P_7-16x1-1-2)
21	Nylon Insert lock Nut 5/16" n.c. GR5	Écrou à garniture de nylon 5/16" n.c. GR5	5	O/L (335NC.P_5-16)
22	Lock washer 1/4"	Rondelle de blocage 1/4"	1	O/L (362.P_1-4)
23	Lock washer 5/16"	Rondelle de blocage 5/16"	4	O/L (362.P_5-16)
24	Lock washer 7/16"	Rondelle de blocage 7/16"	1	O/L (362.P_7-16)
25	Tie wrap 8" (black), 50lbs, Weather & UV-Resistant nylon 6.6	Attache de nylon 8" (noir) ,50lbs, Weather & UV-Resistant nylon 6.6	2	O/L (426-8)

O/L = Obtain Locally / Obtenir localement

Part numbers starting with 500XXX are not available for sale, however, separate parts are available for sale individually.

Les numéros 500xxx ne sont pas disponibles pour la vente. Au besoin, veuillez commander les numéros de pièces séparément.

**NOMENCLATURE ET LISTE DES PIÈCES / PARTS BREAKDOWN & PART LIST**  
**Lame assemblées #501689**  
**Blades assembly #501689**

REF.	ENGLISH DESCRIPTION	DESCRIPTION FRANÇAISE	QTY.	PART#
1	Round stump jumper	Saute obstacle rond	1	111147
2	Cutter blade 15.75" x 3"	Lame 15.75" x 3"	2	111107
3	Blade shim	Espaceur de lame	2	111154
4	Cutter blade bolt	Boulon pour lame de coupe	2	107515
5	Flat washer 1-3/16 (hole) structural	Rondelle plate 1-3/16 (trou) structurelle	2	111458
6	Stover lock nut 1-1/8 N.F.	Écrou de blocage 1-1/8 N.F.	2	111459

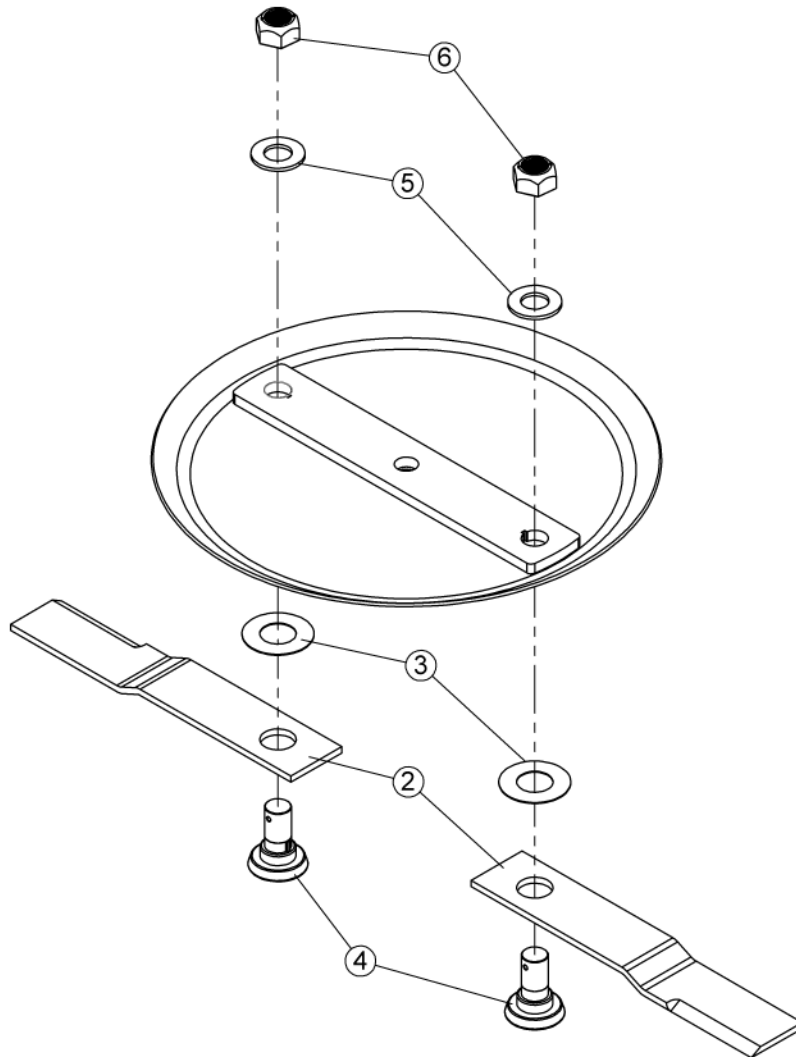

O/L = Obtain Locally / Obtenir localement

Part numbers starting with 500XXX are not available for sale, however, separate parts are available for sale individually.

Les numéros 500xxx ne sont pas disponibles pour la vente. Au besoin, veuillez commander les numéros de pièces séparément.

**NOMENCLATURE ET LISTE DES PIÈCES / PARTS BREAKDOWN & PART LIST**  
**Boîte de contrôle assemblée avec câble #501337**  
**Control box assembly with cable #501337**

REF.	ENGLISH DESCRIPTION	DESCRIPTION FRANÇAISE	QTY.	PART#
1	Control box assembly	Boîte de contrôle assemblée	1	501325
2	Spring bracket	Fixation du ressort	1	102210
3	Throttle arm	Bras d'accélérateur	1	102541
4	Handle grip	Poignée de plastique	1	102546
5	Cable shield	Gaine de câble	1	108294
6	Inner wire	Broche intérieure	1	108295
7	Hex. bolt 5/16" n.c. x 3/4" GR5	Boulon hex. 5/16" n.c. x 3/4" GR5	2	O/L (300NC.5P_5-16x3-4)
8	Flange nut 5/16" n.c.	Écrou à bride 5/16" n.c.	1	O/L (334NC.P_5-16)
9	Stover lock nut 5/16" n.c.	Écrou de blocage 5/16" n.c.	1	O/L (338NC.P_5-16)
10	Flat washer 3/8" hole	Rondelle plate 3/8" trou	1	O/L (360.P_3-8T)
11	Belleville washer 3/8"	Rondelle Belleville 3/8"	1	102144
12	Box	Boîte	1	108255
13	Metal screw P.H. #8 x 1/4"	Vis à métal P.H. #8 x 1/4"	4	O/L (400.P_8x1-4)

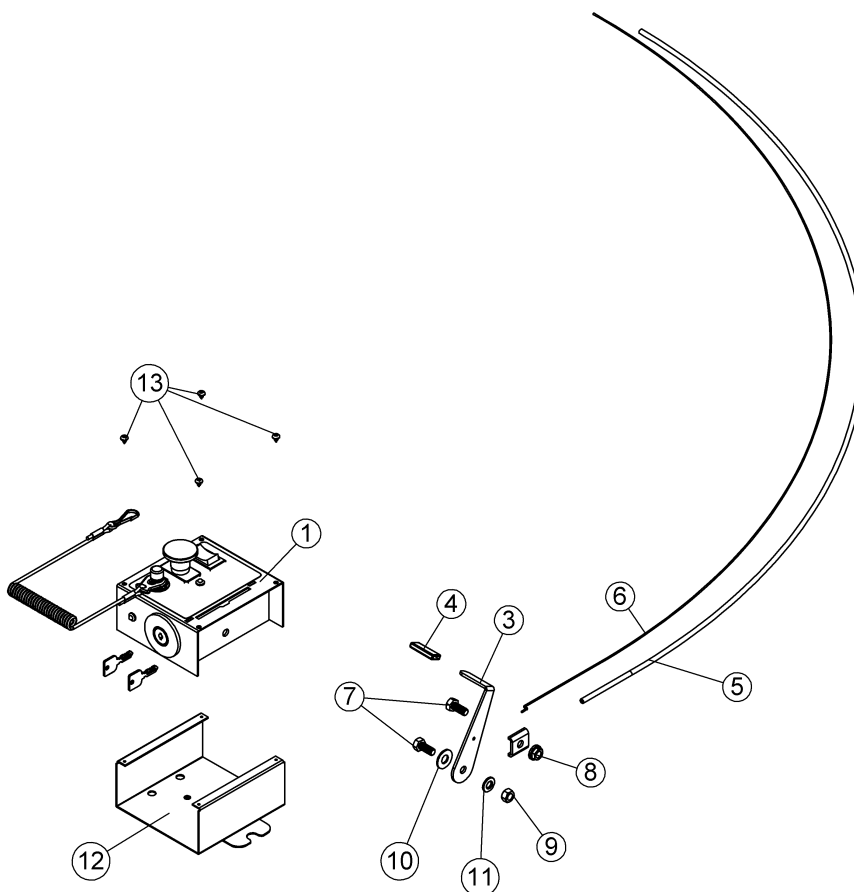

O/L = Obtain Locally / Obtenir localement

Part numbers starting with 500XXX are not available for sale, however, separate parts are available for sale individually.

Les numéros 500xxx ne sont pas disponibles pour la vente. Au besoin, veuillez commander les numéros de pièces séparément.

**NOMENCLATURE ET LISTE DES PIÈCES / PARTS BREAKDOWN & PART LIST**  
Boîte de contrôle assemblée #501325  
Control box assembly #501325

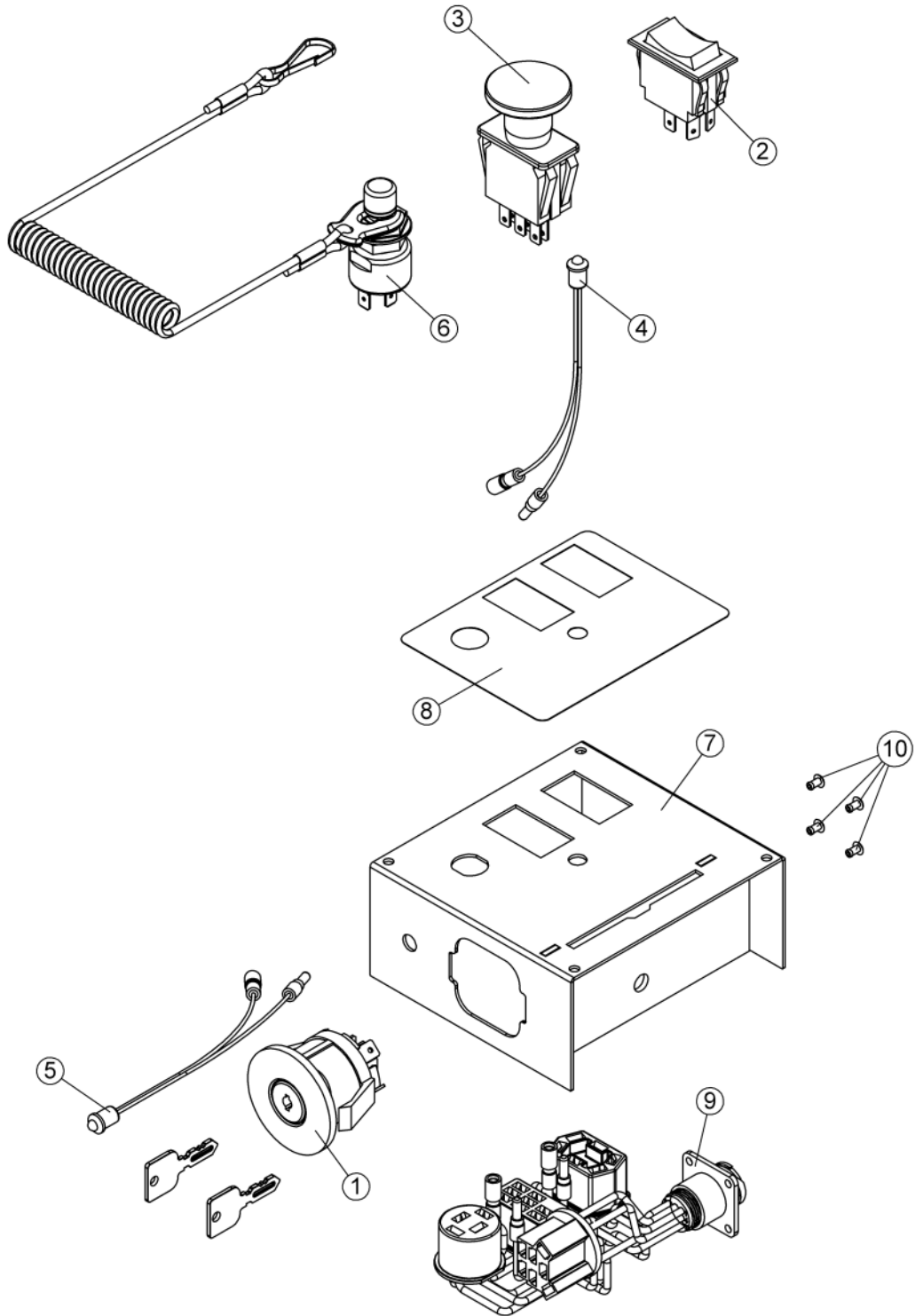

**NOMENCLATURE ET LISTE DES PIÈCES / PARTS BREAKDOWN & PART LIST**  
**Boîte de contrôle assemblée #501325**  
**Control box assembly #501325**

REF.	ENGLISH DESCRIPTION	DESCRIPTION FRANÇAISE	QTY.	PART#
1	Ignition switch	Commutateur d'ignition	1	104015
2	Switch	Commutateur	1	107446
3	Emergency switch	Interrupteur d'urgence	1	107447
4	Warning light	Avertisseur lumineux	1	107456
5	Warning light	Avertisseur lumineux	1	107457
6	Emergency switch with lanyard	Interrupteur d'urgence avec cordon	1	107472
7	Box cover	Couvercle de la boîte	1	107579
8	Control box decal	Décalque de la boîte de contrôle	1	107628
9	Control box wire assembly	Fil assemblé de la boîte de contrôle	1	108660
10	Pop-rivet 1/8" x 3/16" no.AD-43BS	Rivet pop 1/8" x 3/16" no.AD-43BS	4	O/L (415_1-8x3-16)

O/L = Obtain Locally / Obtenir localement

Part numbers starting with 500XXX are not available for sale, however, separate parts are available for sale individually.

Les numéros 500xxx ne sont pas disponibles pour la vente. Au besoin, veuillez commander les numéros de pièces séparément.

## NOMENCLATURE ET LISTE DES PIÈCES / PARTS BREAKDOWN & PART LIST

Garde assemblé #501019

Guard assembly #501019

REF.	ENGLISH DESCRIPTION	DESCRIPTION FRANÇAISE	QTY.	PART#
1	Guard	Garde	1	107337
2	Rubber strap	Sangle en caoutchouc	1	107363
3	Knob	Bouton	1	106861
4	O-Ring	Anneau d'étanchéité	1	108313
5	Hex. bolt 1/4" n.c. x 1 1/4" GR5	Boulon hex. 1/4" n.c. x 1 1/4" GR5	1	O/L (300NC.5P_1-4x1-4)
6	Hex. bolt 5/16" n.c. x 3/4" GR5	Boulon hex. 5/16" n.c. x 3/4" GR5	1	O/L (300NC.5P_5-16x3-4)
7	Nylon Insert lock Nut 5/16" n.c. GR5	Écrou à garniture de nylon 5/16" n.c. GR5	1	O/L (335NC.P_5-16)
8	Flat washer 1/4" hole	Rondelle plate 1/4" trou	1	O/L (360.P_1-4T)
9	Flat washer 3/8" hole	Rondelle plate 3/8" trou	1	O/L (360.P_3-8T)

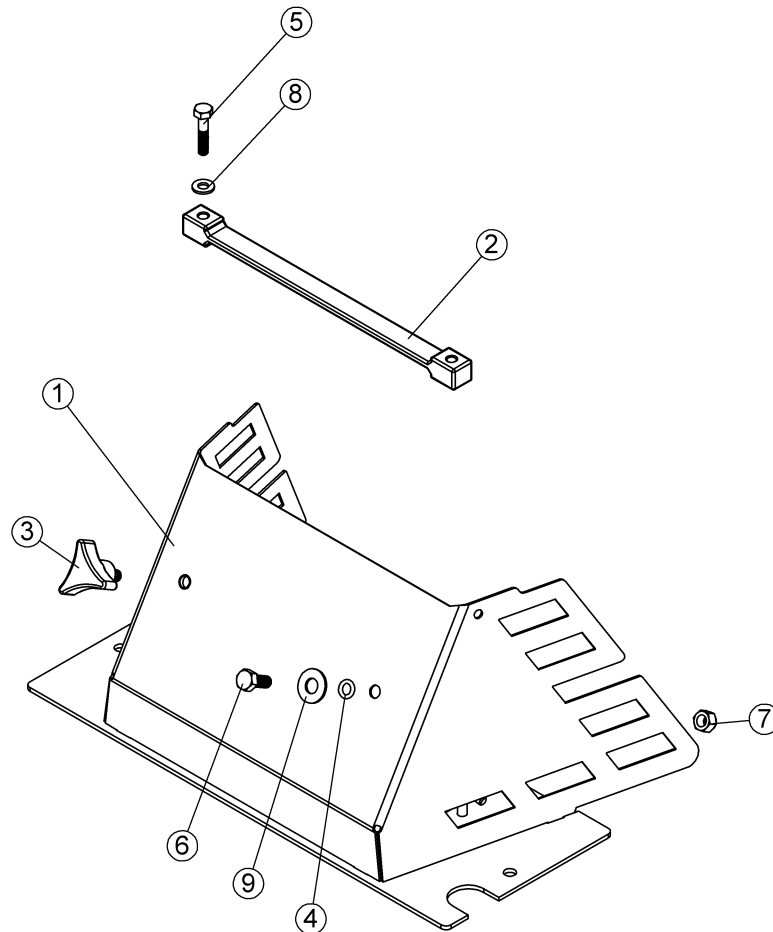

O/L = Obtain Locally / Obtenir localement

Part numbers starting with 500XXX are not available for sale, however, separate parts are available for sale individually.

Les numéros 500xxx ne sont pas disponibles pour la vente. Au besoin, veuillez commander les numéros de pièces séparément.

**NOMENCLATURE ET PIÈCES DE SERVICE**  
**PARTS BREAKDOWN & SERVICE PARTS**  
 Panneau électrique #108236  
 Electric board #108236

REF.	ENGLISH DESCRIPTION	DESCRIPTION FRANÇAISE	QTY.	PART#
1	Relay	Relais	3	104405
2	Relay	Relais	1	107274
3	Relay connector	Connecteur de relais	3	107501
4	Relay connector key	Clef du connecteur de relais	3	107502
5	Wire assembly (Red Rubber)	Fil assemblé (Caoutchouc rouge)	1	108308
6	Wire assembly (Orange Rubber)	Fil assemblé (Caoutchouc orange)	1	108581
7	Breaker	Disjoncteur	6	107600
8	Connector kit	Ensemble de connecteur	1	108564
9	Connector kit	Ensemble de connecteur	1	108565

**Note :**

L'item #9 n'est pas inclus avec 108236.  
 The item #9 is not included with 108236.

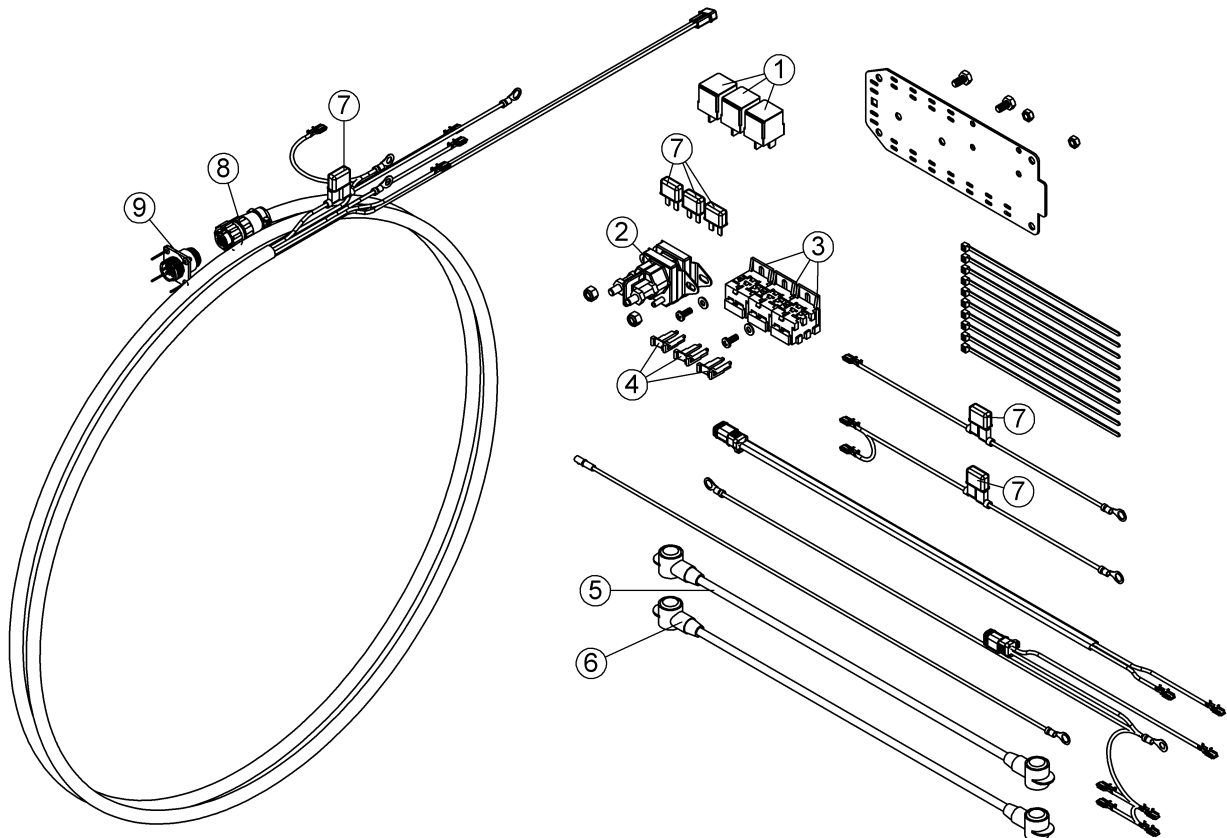

O/L = Obtain Locally / Obtenir localement

Part numbers starting with 500XXX are not available for sale, however, separate parts are available for sale individually.

Les numéros 500xxx ne sont pas disponibles pour la vente. Au besoin, veuillez commander les numéros de pièces séparément.







# TORQUE SPECIFICATION TABLE

## GENERAL TORQUE SPECIFICATION TABLE USE THE FOLLOWING TORQUES WHEN SPECIAL TORQUES ARE NOT GIVEN

**NOTE:** These values apply to fasteners as received from supplier, dry or when lubricated with normal oil. They do not apply if special graphited or moly disulphide greases or other extreme pressure lubricants are used. This applies to both UNF and UNC threads.

\* Thick nuts must be used with grade 8 bolts

SEE Grade No.		2				5				8 *			
BOLT HEAD IDENTIFICATION MARKS AS PER GRADE NOTE MANUFACTURING MARKS WILL VARY		TORQUE				TORQUE				TORQUE			
BOLT SIZE		FOOT POUNDS		NEW TON-METERS		FOOT POUNDS		NEW TON-METERS		FOOT POUNDS		NEW TON-METERS	
Inches	Millimetre	Min.	Max.	Min.	Max.	Min.	Max.	Min.	Max.	Min.	Max.	Min.	Max.
1/4"	6.35	5	6	6.8	8.13	9	11	12.2	14.9	12	15	16.3	30.3
5/16"	7.94	10	12	13.6	16.3	17	20.5	23.1	27.8	24	29	32.5	39.3
3/8"	9.53	20	23	27.1	31.2	35	42	47.5	57	45	54	61	73.2
7/16"	11.11	30	35	40.7	47.4	54	64	73.2	86.8	70	84	94.9	113.9
1/2"	12.7	45	52	61	70.5	80	96	108.5	130.2	110	132	149.2	179
9/16"	14.29	65	75	88.1	101.6	110	132	149.2	179	160	192	217	260.4
5/8"	15.88	95	105	128.7	142.3	150	180	203.4	244.1	220	264	298.3	358
3/4"	19.05	150	185	203.3	250.7	270	324	366.1	439.3	380	456	515.3	618.3
7/8"	22.23	160	200	216.8	271	400	480	542.4	650.9	600	720	813.6	976.3
1"	25.4	250	300	338.8	406.5	580	696	786.5	943.8	900	1080	1220.4	1464.5

METRIC BOLT TORQUE SPECIFICATIONS							
		COARSE THREAD			FINE THREAD		
Size Screw	Grade No.	Pitch (mm)	Foot Pounds	Newton-Meters	Pitch (mm)	Foot Pounds	Newton-Meters
M6	4T	1.00	3.6 - 5.8	4.9 - 7.9	-	-	-
	7T		5.8 - 9.4	7.9 - 12.7		-	-
	8T		7.2 - 10	9.8 - 13.6		-	-
M8	4T	1.25	7.2 - 14	9.8 - 19	1.00	12 - 17	16.3 - 23
	7T		17 - 22	23 - 29.8		19 - 27	25.7 - 36.6
	8T		20 - 26	27.1 - 35.2		22 - 31	29.8 - 42
M10	4T	1.50	20 - 25	27.1 - 33.9	1.25	20 - 29	27.1 - 39.3
	7T		34 - 40	46.1 - 54.2		35 - 47	47.4 - 63.7
	8T		38 - 46	51.5 - 62.3		40 - 52	54.2 - 70.5
M12	4T	1.75	28 - 34	37.9 - 46.1	1.25	31 - 41	42 - 55.6
	7T		51 - 59	69.1 - 79.9		56 - 68	75.9 - 92.1
	8T		57 - 66	77.2 - 89.4		62 - 75	84 - 101.6
M14	4T	2.00	49 - 56	66.4 - 75.9	1.50	52 - 64	70.5 - 86.7
	7T		81 - 93	109.8 - 126		90 - 106	122 - 143.6
	8T		96 - 109	130.1 - 147.7		107 - 124	145 - 168
M16	4T	2.00	67 - 77	90.8 - 104.3	1.50	69 - 83	93.5 - 112.5
	7T		116 - 130	157.2 - 176.2		120 - 138	162.6 - 187
	8T		129 - 145	174.8 - 196.5		140 - 158	189.7 - 214.1
M18	4T	2.00	88 - 100	119.2 - 136	1.50	100 - 117	136 - 158.5
	7T		150 - 168	203.3 - 227.6		177 - 199	239.8 - 269.6
	8T		175 - 194	237.1 - 262.9		202 - 231	273.7 - 313
M20	4T	2.50	108 - 130	146.3 - 176.2	1.50	132 - 150	178.9 - 203.3
	7T		186 - 205	252 - 277.8		206 - 242	279.1 - 327.9
	8T		213 - 249	288.6 - 337.4		246 - 289	333.3 - 391.6

# LIMITED WARRANTY

## **Conditions and Products Covered:**

BERCOMAC guarantees any part of the product or accessory manufactured by BERCOMAC and found in the reasonable judgment of BERCOMAC to be defective in material and or workmanship will be repaired or replaced by an authorized dealer without charge up to our maximum labor rates and pre-established times. For replacement parts only standard ground freight services are covered. This warranty extends to the original retail purchaser only and is not transferable to any subsequent purchasers. This warranty applies to the products bought and used in North America.

## **Warranty Period**

(from date of the original retail purchase)

- Residential or semi-commercial use: 1 year
- Commercial, industrial or rental use: 90 days

**Exceptions Noted Below;** the following items are guaranteed by the original manufacturer and have their own warranty, conditions and limited time:

- Tire Chains:
  - 90 days residential or semi-commercial use
  - No warranty on other application
- Engines: Will vary as per the manufacturer  
Please refer to the engine manufacturer's warranty statement included with the unit. BERCOMAC is not authorized to handle warranty adjustments on engines.

## **Items and Conditions NOT Covered:**

This warranty does not cover the following:

- Pick-up or delivery charges or in-home services fees.
- Any damage or deterioration of the unit, parts and or finish of these due to normal use, wear and tear, or exposure.
- Cost of regular use or maintenance service or parts, such as gas, oil, lubricants, tune-up parts, and adjustments.
- Any part or accessory which has been altered, modified, misused, neglected, accidentally damaged or not properly installed, maintained, stored or repaired not in accordance with the instructions in the owner's manual.
- Repair due to normal wear and or any wear items such as shear pins, bolts, belts, winch cable, cutting edge, skid shoes, etc.
- Expedited freight fee services for replacement parts.
- Shear bolts and shear pins are to be considered as a preventive measure not as an assured protection, any damages resulting from the lack of shear bolts breakage are not covered.
- Damages due to product being installed on vehicle other than stipulated in the owner's manual.

NOTE: All warranty work must be performed by an authorized dealer using original (manufacturer) replacement parts.

**NOTE:** Bercomac reserves the right to change or improve the design of any part or accessory without assuming any obligation to modify any product previously manufactured.

## **Instructions for Obtaining Warranty Services:**

Contact dealer where equipment was purchased or any other BERCO service dealer to arrange service at their dealership. To locate a dealer convenient to you, access our website at [www.bercomac.com](http://www.bercomac.com). Don't forget to bring your proof of purchase (sales receipt) to the BERCO dealer.

## **Owner's Responsibilities:**

BERCOMAC's defective equipment or part must be returned to an authorized dealer within the warranty period for repairs. In the event that defective merchandise must be returned to manufacturer for repairs, freight fees are prepaid and a written authorization from BERCOMAC must be obtained by dealer prior to the shipment. This warranty extends only to equipment operated under normal conditions. To validate a warranty claim, it is the user's responsibility to maintain and service the unit as specified in the owner's manual or to have the unit serviced at their dealer at their expense.

## **General Conditions:**

The sole liability of BERCOMAC with respect to this warranty shall be strictly and exclusively repair and replacement as mentioned herein. BERCOMAC shall not have any liability for any other costs, loss or damage, including but not limited to, any incidental or consequential loss or damage.

Taking advantage of the warranty does not in any way extend the length or renewal of the warranty.

In particular, without being limited to, BERCOMAC shall have no liability or responsibility for:

- Travel time, overtime, after hours time or other extraordinary repair charges or relating to repairs and or replacements outside of normal business hours.
- Rental of like or similar replacement equipment during the period of any, repair or replacement work.
- Any communicating or travel charges.
- Loss or damage to person or property other than that covered by the terms of this warranty.
- Any claims for lost revenue, lost profit or any similar costs as a result of damage or repair.
- Attorney's fees.

BERCOMAC's responsibility in respect to claims is limited to making the required repairs or replacement without charge up to our maximum labor rates and pre-established times and no claim of breach of warranty shall be cause for cancellation or rescission of the contract of sale of any product or accessory. In no event shall recovery of any kind be greater than the amount of the purchase price of the product sold.

This warranty gives you specific legal rights. You may also have other rights, which vary from state to state.



***WHEN PERFORMANCE  
& DEPENDABILITY  
ARE NON NEGOTIABLE !***

**Bercomac Limitée  
92, Fortin North, Adstock, Quebec, Canada, G0N 1S0**

***WWW.BERCOMAC.COM***

**PRINTED IN CANADA**

**(ORIGINAL NOTICE)**