



# OWNER'S MANUAL

***Model Number***

**701015-2**



## ***BERCO*** ***GRAPPLE*** FOR **Compact tractor**

**\*ASSEMBLY**  
**\*OPERATION**

**\*REPAIR PARTS**  
**\*MAINTENANCE**

### **CAUTION:**

**READ & FOLLOW ALL SAFETY RULES & INSTRUCTIONS BEFORE  
OPERATING YOUR EQUIPMENT**



# Table of content

---

## Table of content

Introduction .....	1	Vehicle shutdown procedures .....	17
Important safety information .....	2	Hooking-Up the accessory .....	17
Safety alert symbol/Signal words/Safety messages .....	2	Unhooking the accessory .....	17
Assembly & initial set-up .....	6	Picking-up a load .....	18
Vehicle requirements .....	6	Traveling with a load .....	19
Reception .....	6	Releasing a load .....	19
Assembly general instructions .....	7	Pull up bushes .....	19
Accessory assembly .....	7	Adjustments.....	21
Installing the adapters on the cylinders.....	7	Parking stand.....	21
Connecting hoses to adapters.....	7	Lower the parking stands:.....	21
Installation of hoses and cylinders to the frame.....	8	Raising the parking stand:.....	21
Installation of the hydraulic hoses .....	9	Troubleshooting.....	22
Initial set-up.....	11	Maintenance.....	23
Accessory Hook-up & Unhook .....	12	Maintenance schedules.....	23
Skid steer quick attach Style .....	12	Storage and transportation .....	24
Hose Hook-Up .....	13	Long-Term Storage .....	24
Purging the hydraulic system .....	14	Transportation.....	24
Equipment clearances.....	14	Specifications .....	25
Unhooking the accessory .....	15	Part list and parts breakdown.....	26
Operating instructions .....	16	Torque specification table .....	31
Safety precaution .....	16	Hydraulic fitting assembly chart.....	32
Controls and display .....	17		
Operating instructions.....	17		
Pre-start instructions .....	17		

# Introduction

---

## Introduction

### To the purchaser

This new accessory was carefully designed to give years of dependable service. This manual has been provided to assist in the safe operation and servicing of your attachment.

All photographs, illustrations and information in the manual may not necessarily depict the actual models or attachments, but are intended for reference only and are based on the latest product information available at the time of publication.

Familiarize yourself fully with the safety recommendations, assembly, operating procedures, adjustments, troubleshooting, and maintenance before putting the machine to use. It's a necessity for all operators to carefully read, understand and follow these recommendations and insist that they be followed by those who will use this attachment. This manual should be kept for future reference.

Please check if you have received all the parts for your kit with the list of the bag and the list of the box.

### Serial number

If applicable, record the serial number and purchase date of your attachment in the section reserved below. Your dealer will require this information to give you prompt, efficient service when ordering replacement parts. Use only genuine parts when replacements are required.

If applicable, the location of the serial number on the accessory is shown in the parts breakdown & part list section of this manual.

**SERIAL NUMBER** \_\_\_\_\_ **MODEL NUMBER** \_\_\_\_\_

**PURCHASE DATE** \_\_\_\_\_

If warranty repairs are required please present this registration booklet and original sales invoice to your selling dealer for warranty service.

### Terminology

- "Accessory" is used as a general word to describe the product covered in this manual.
- The "right" and "left" side is determined by sitting in the driver's seat facing forward.
- "Vehicle" is a general term to describe the vehicle (tractor, atv, utv, garden tractor,...) the accessory is installed

### Further Assistance

If you need any assistance in understanding the information given in the manual and other concerns regarding operation of the machine or for repair parts, safety decals,...

1. Ask your dealership's service representative.
2. If you are not satisfied, seek for general manager of dealership or service manager.
3. If you are still not satisfied, contact us at the address specified on the back page of this manual.

### Application

This grapple is designed to be used to move light materials such as branches, hay, and other light debris. It also can be used to pull up bushes.

# Important safety information

## Safety alert symbol/Signal words/Safety messages

These are common practices that may or may not be applicable to the product described in this manual.

### SAFETY ALERT SYMBOL



**THIS SAFETY ALERT SYMBOL IDENTIFIES AN IMPORTANT SAFETY MESSAGE IN THIS MANUAL THAT HELPS YOU AND OTHERS AVOID PERSONAL INJURY OR EVEN DEATH. DANGER, WARNING, AND CAUTION ARE SIGNAL WORDS USED TO IDENTIFY THE LEVEL OF HAZARD. HOWEVER, REGARDLESS OF THE HAZARD, BE EXTREMELY CAREFUL.**

**⚠ DANGER:** Signals an extreme hazard that will cause serious injury or death if recommended precautions are not followed.

**⚠ WARNING:** Signals a hazard that may cause serious injury or death if the recommended precautions are not followed.

**⚠ CAUTION:** Signals a hazard that may cause minor or moderate injury if the recommended precautions are not followed.

### PREPARATION FOR USE

All operators, no matter how experienced they may be, should read and understand this and other manuals related to the vehicle and accessory before operating. It is the owner's legal obligation to instruct all operators in safe operation of the accessory to prevent injury or death. Improper use of the accessory can cause serious injury or death.

- Read and understand this owner's manual carefully. Be thoroughly familiar with the controls and proper use of the vehicle and accessory. Know how to stop the unit and handle the controls quickly in case of emergency.
- Read and understand the "Safety Decals" section, read all instructions noted on them or/and in the "Safety Decals" section.
- Never allow children to operate the vehicle nor the accessory. Never allow adults to operate or maintain the vehicle nor the accessory without proper instructions. Local regulations restrict the age of the operator.
- Children are often attracted to accessories. Never assume children will stay in place where you have last seen them. Keep children under surveillance of a responsible adult at all times.
- No one should operate the vehicle nor the accessory while intoxicated or while taking medication that impairs the senses or reactions. The operator should, if taking medication, seek

medical advice on whether he/she can safely operate the equipment.

- Keep the area of operation clear of all people, particularly small children.
- Never start or operate the accessories except from the operator's seat.
- Prepare for emergencies. Be prepared if a fire starts. Keep first aid kit and fire extinguisher handy. Keep emergency phone numbers (doctor, ambulance, etc) near a phone.
- Thoroughly inspect the area where the accessory is to be used and remove door mats, wires, and other foreign objects .
- For motorized accessories, disengage all clutches and shift into neutral before starting engine.
- Do not operate or maintain the accessory without wearing adequate clothing and safety equipment. (glasses, muffs, earplugs, mask...) Wear footwear that will improve footing on slippery surfaces. Prolonged exposure to loud noise can cause hearing impairment or hearing loss.
- Clothing should be snug without fringes and pull strings to avoid entanglement with moving parts.
- Avoid wearing radio headphones while operating.

# Important safety information

---

- Handle fuel with care, it is highly flammable and vapors are explosive.
  - a) Extinguish all cigarettes, cigars, pipes and other sources of ignition.
  - b) Use approved fuel container.
  - c) Never add fuel to a running engine or hot engine.
  - d) Fill fuel tank outdoors with extreme care. Never fill fuel tank indoors.
  - e) Never fill containers inside a vehicle, on a truck or a trailer bed with a plastic liner. Always place containers on the ground, away from your vehicle, before filling.
  - f) When possible, remove gas-powered equipment from the truck or trailer and refuel it on the ground. If this is not possible, then refuel such equipment on a trailer with a portable container, rather than directly from a gasoline dispenser nozzle.
  - g) Keep the nozzle in contact with the rim of the fuel tank or container opening at all times, until refueling is complete. Do not use a nozzle lock-open device.
  - h) Never overfill fuel tank. Replace fuel cap securely and wipe up spilled fuel.
  - i) If fuel is spilled on clothing, change clothing immediately.
- Never attempt to make any adjustments while the engine (motor) is running (except when specifically recommended by manufacturer).
- Let the vehicle and accessory adjust to outdoor temperatures before using.
- Always make sure to have safe traction on the vehicle by using the recommended accessories (chains, tracks, counterweights...). See operation section.
- Always make sure all components are correctly installed. (driveline securely attached and locked at both ends, belts properly installed...)
- Never modify the accessory or any part without the written consent from the manufacturer. Use only options/accessories approved by the manufacturer
- Avoid underground utilities. If the accessory digs into the ground, always contact your local utility companies (electrical, water, gas,...) before digging to know where you can dig.
- Exercise extreme caution when operating on or crossing gravel drives, walks or roads. Stay alert for hidden hazards such as traffic, fences, trees, buildings, wires, etc.
- After striking a foreign object, stop the engine (motor), disconnect the wire from the spark plug(s) and keep wire away to prevent accidental starting. Thoroughly inspect the accessory for any damage and repair damage before restarting and using the accessory.
- If the unit should start to vibrate abnormally, stop the engine (motor) and check immediately for the cause. Vibration is generally a warning of trouble. Do not use equipment until properly repaired.
- Take all possible precautions when leaving the operator's seat. Disengage the power take-off, lower the accessory, place the transmission into neutral, set the parking brake, stop the engine and remove the ignition key to prevent unauthorized starting then wait for all components to come to a complete stop before leaving operator's seat.
- Do not run the engine indoors, except when starting the engine and for transporting in or out of the building. Do not operate or let motor run in a storage area without ventilation because gas contains carbon monoxide which is odorless, colorless and can cause death.
- Never use the accessories across the face of slopes. Go from top to bottom. Exercise extreme caution when using equipment on slopes, on wet ground or near a drop-off. Do not attempt to use accessory on a steep slope.
- Never tolerate bystanders in the working zone or between the vehicle and accessory while hooking-up the accessory.
- Never operate the accessory at high transport speeds. Move and turn vehicle at low speeds during operation. Be cautious when backing up.
- Do not carry or lift passengers on vehicle or accessory.
- Disengage power to the accessory when it is transported or not in use.
- Never operate the accessory without good visibility or light.
- Keep the accessory away from heat sources or flames.
- Never use accessory if it has been dropped or damaged. Repair if necessary before re-using.
- Never use an accessory without proper guards, plates, or other safety protective devices in place

## OPERATION:

- Do not put hands or feet near, under or inside rotating parts or any power driven parts

# Important safety information

---

## TRANSPORT

- Review Transport Safety instructions in the vehicle manual before moving or hauling.
- Check with local authorities regarding transport on public roads and off road. Comply to all applicable laws and regulations.
- Make sure all lights and reflectors that are required by the local highway and transport authorities (example : SMV (Slow Moving Vehicle), flashing warning light) are in place, are clean, and can be seen clearly by all overtaking and oncoming traffic. Turn on flashing warning light whenever on a highway, except where such is prohibited by law.
- Never have the equipment in operation during transport.
- Always travel at a safe and slow speed to allow adequate steering control and stopping
- Always drive with accessory low to the ground but high enough to avoid any contact with road or any foreign objects during transportation
- Avoid any contact with any overhead power line.
- Never drive the accessories across the face of slopes. Go from top to bottom or bottom to up
- Engage parking brake when stopped on an incline
- Allow for the accessory length when making turns.

## MAINTENANCE AND ADJUSTMENT

- When cleaning, repairing or inspecting the vehicle and accessory: park on a solid level ground (in a clean dry area), disengage drives, lower implement, set parking brake, stop the engine, remove ignition key, and wait that all moving parts have stopped and cooled. For gasoline engine, disconnect wire from the spark plug(s) and keep wire away to prevent accidental starting.
- Allow the accessory to cool before working on it
- Use a jack and support blocks to support equipment when required. Carefully release pressure from equipment with stored energy.
- Check all the bolts and components at frequent intervals to make sure that they are properly tightened and in safe working condition.
- When inflating tires, stand on one side NOT in front or over the tire assembly. Use a safety cage if available.
- Remove grease, oil, or debris build-ups.

Remove all tools and unused parts from equipment before operation.



- Disconnect battery ground cable (-) before servicing or adjusting electrical systems or before welding on implement
- Replace parts on this accessory with genuine part only.
- Understands maintenance and adjustment procedure, see adjustment and maintenance section of the owner's manual.
- Never work or walk under the accessory unless securely blocked. Otherwise accessory can fall.
- Visually check for hydraulic leaks and broken, missing, or malfunctioning parts and make necessary repairs before applying pressure to the system. Do the same validation after applying pressure to the system (use a piece of cardboard not your hands to detect leaks).
- Escaping hydraulic oil under pressure can have sufficient force to penetrate skin, causing serious personal injury. If injured by escaping fluid, obtain medical treatment immediately.
- Wear protective gloves and safety glasses or goggles when working with hydraulic system.
- Before disconnecting hydraulic line or performing work, relieve all hydraulic pressure

## STORAGE

- Never store a motorized accessory with fuel in the fuel tank inside a building where ignition sources are present such as hot water and space heaters, clothes dryers, and the like. Allow the engine to cool before storing in any enclosure.
- Always refer to the owner's manual when you store the accessory and vehicle for a prolonged or an unspecified length of time.
- Maintain or replace safety and instruction labels, as necessary.
- For winter accessories, (if applicable), let the engine run for a few minutes after clearing snow in order to prevent the rotary parts from freezing.
- Always refer to operator's manual for important details if the accessory is to be stored for an extended period
- Store the accessory in an area where children normally do not play. Secure the implement using blocks and supports and secure any pointy or sharp edges.

# Important safety information

## Safety decals

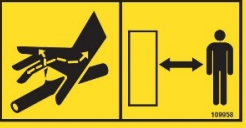
Symbol	Decal #	Description
	#108750	<p>Risk of getting pinched:</p> <p>To avoid serious injuries, keep away from moving parts. Securely and safely immobilize moving parts before doing any maintenance on them.</p>
	#109957	<p>Before installing or using:</p> <p>Locate, read and make sure to understand all the owner's manual.</p>
	#109958	<p>High pressure fluid hazard:</p> <p>To avoid serious injuries or death:</p> <ul style="list-style-type: none"> <li>• Always keep your distance with pressurized hydraulic hoses</li> <li>• Relieve pressure on system before repairing or adjusting or disconnecting.</li> <li>• Wear proper hand and eye protection when searching for leaks. Use wood or cardboard instead of hands.</li> <li>• Keep all components in good repair.</li> </ul>

## Assembly & initial set-up

### Vehicle requirements

The grapple is designed to attach to tractor loader:

The grapple is compatible with:

- Compact tractor with up to 30 hp engine
- Compact tractor weighing less than 3000 lbs
- Maximum working pressure of 2400psi
- Tractor equipped with universal quick attach “skid steer type”

Tractor needs a third function valve or available hydraulic connection on the tractor

#### **WARNING**

##### **To avoid serious injury or death:**

Counterweight may be required. Refer to your loader and tractor manual to determine if counterweight is needed. If loader and tractor manual do not have enough information, contact your tractor/loader manufacturer to determine if you need counterweight

#### **WARNING**

##### **To avoid serious injury or death caused by vehicle overturn:**

Operate only with tractor equipped with an approved rollover-protective structure (ROPS) or ROPS cab and seat belt. Foldable ROPS must be kept up and in locked position at all times. Fasten seatbelt snugly and securely.

### Reception

#### **CAUTION**

##### **To avoid serious injury :**

Keep Clear. The accessory can flip forward or backward suddenly causing serious injury while removing the accessory from packaging.

- A. Remove the tarp from the shipping crate, remove the sides of the box and the other items in the shipping crate.

- B. Unbolt the accessory by removing all fasteners that hold it in place in the wooden box.
- C. Using a hoist, forklift, or other lifting device, attach a chain to the grapple at locations 1.

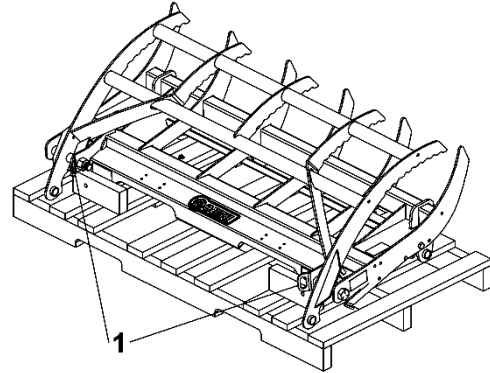

- D. Slowly lift the grapple off the base of the wooden box until it has rotated upright, keep the grapple around 1” off ground.
- E. Lower the two parking stands (item 1) (see adjustments section for more details).

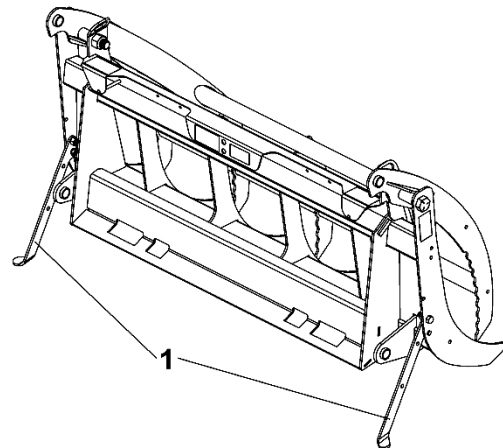

- F. Lower the grapple to the ground (solid and flat surface).
- G. Inspect the grapple to make sure it is stable on the ground and remove chain.

# Assembly and initial set-up

## Assembly general instructions

- Unless otherwise specified, torque all bolts to “torque specification table” (see table of content for page number)
- Refer to parts breakdown section for part identification.

## Accessory assembly



### WARNING

**THIS ACCESSORY AND ALL OPTIONS ARE HEAVY!**

To avoid risk of strain injury, NEVER lift the accessory or any options by hand alone when handling the components or assembly. Use proper lifting device and seek assistance.

When accessory is off the ground, NEVER be underneath the accessory. Serious injury including possibility of death could occur if accessory were to drop suddenly.

Always wear protective shoes and appropriate gloves when manipulating or using this equipment.

## Installing the adapters on the cylinders

**Left and right cylinder:**

Remove the plugs (item 1). Screw the adapters (item 2) in place without immediately tightening the lock nut.

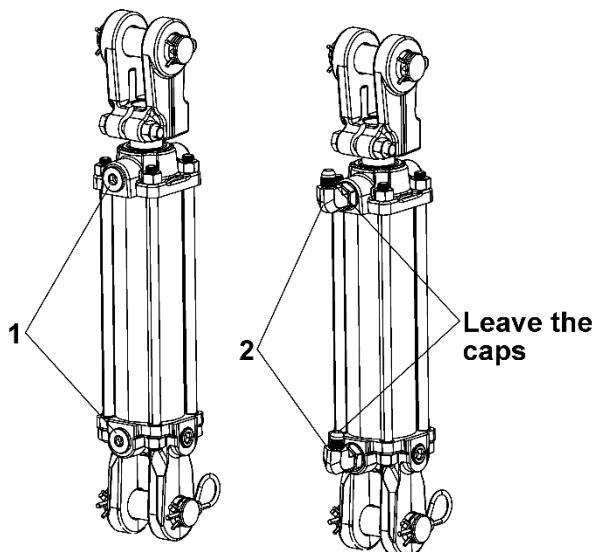

Tighten the adapters to the torques and angles indicated.

**Left cylinder:**

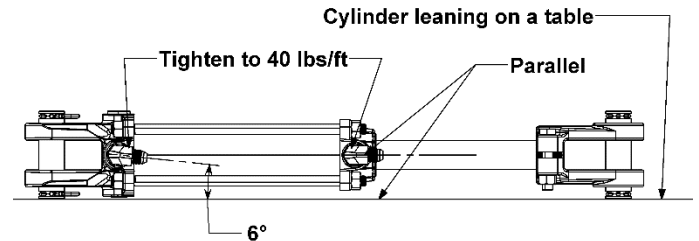

**Right cylinder:**

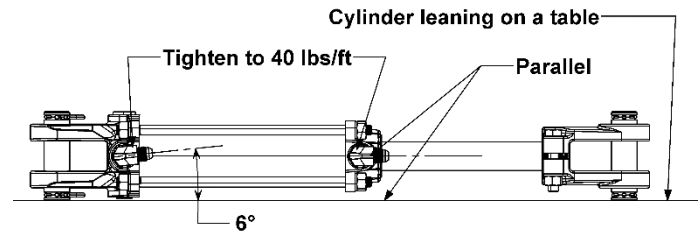

## Connecting hoses to adapters

Screw the hoses (item 1 and 2) on the "T" adapters (item 3), as shown.

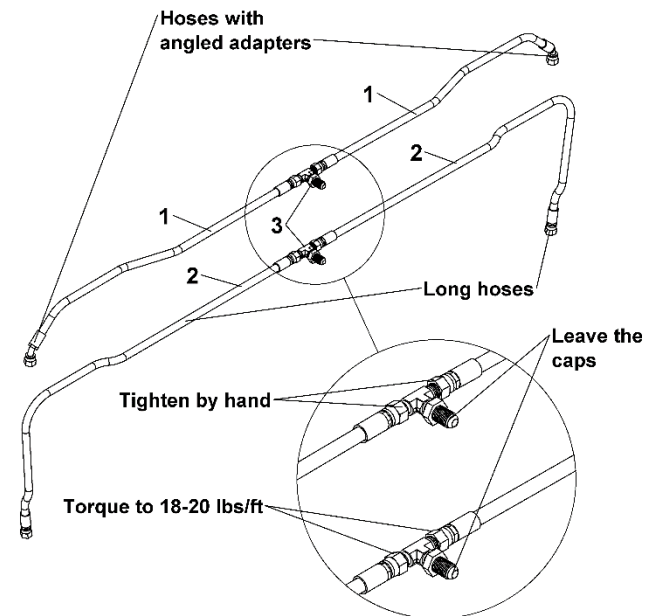

# Assembly and initial set-up

## Installation of hoses and cylinders to the frame

Slide the assembled hose (item 1 (the shortest)) under the guard, as shown. Remove the lock nut and slide the shim (item 2) in place. Leave the assembly in place without replacing the lock nut for now.

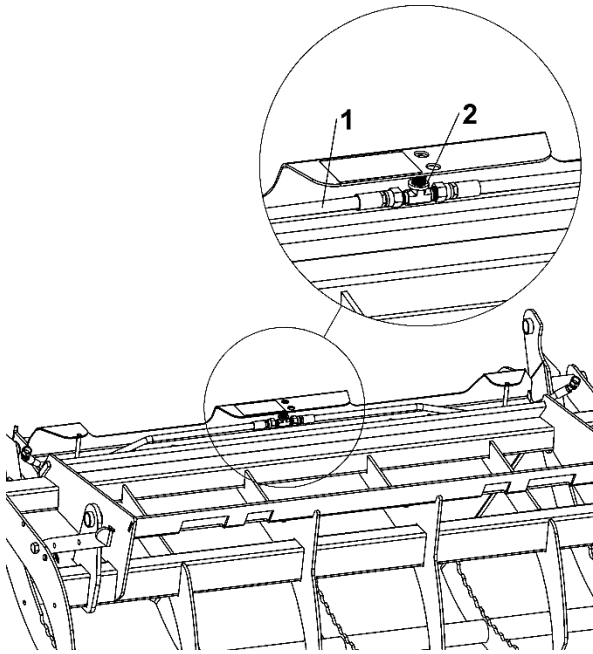

Install the assembled cylinders (left (item 1) and right (item 2)) on the frame by installing the bottom pin first. Tighten the hoses on the cylinders.

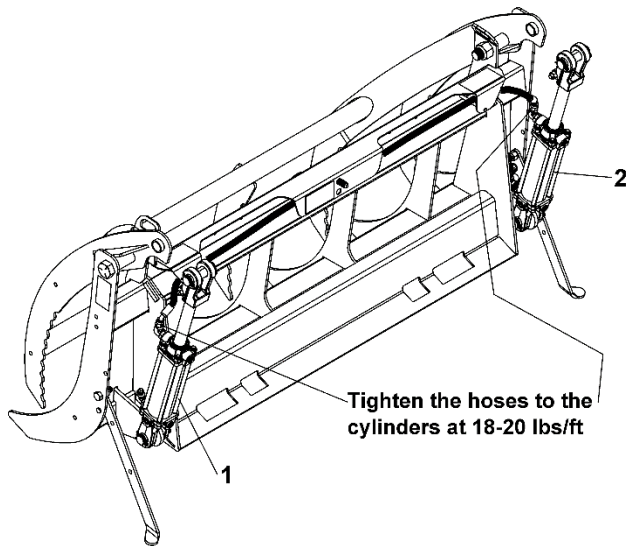

Tighten the hoses at the "T" adapter. Pass the adapter with the shim through the hole and replace the locking nut **without tightening it**.

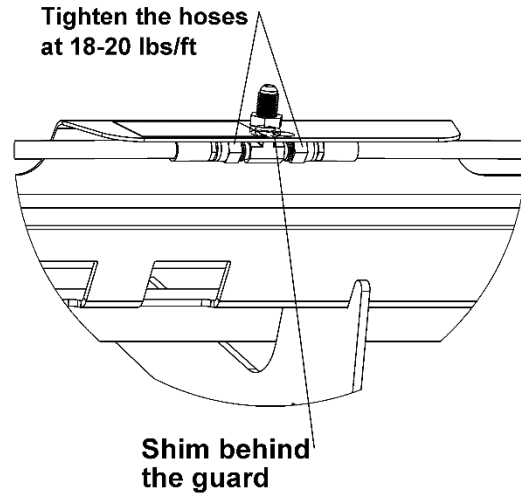

NOTE:  
Tighten the hoses to the required torque always blocking the hose by the hexagon to avoid "rolling up" the hose !

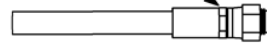

Slide the assembled hose (item 1 (the longest)) under the guard, as shown. Remove the lock nut and slide the shim (item 2) in place. Insert the adapter into the hole and replace the lock nut **without tightening it**. Tighten the hoses on the cylinders and then tighten the two lock nuts.

# Assembly and initial set-up

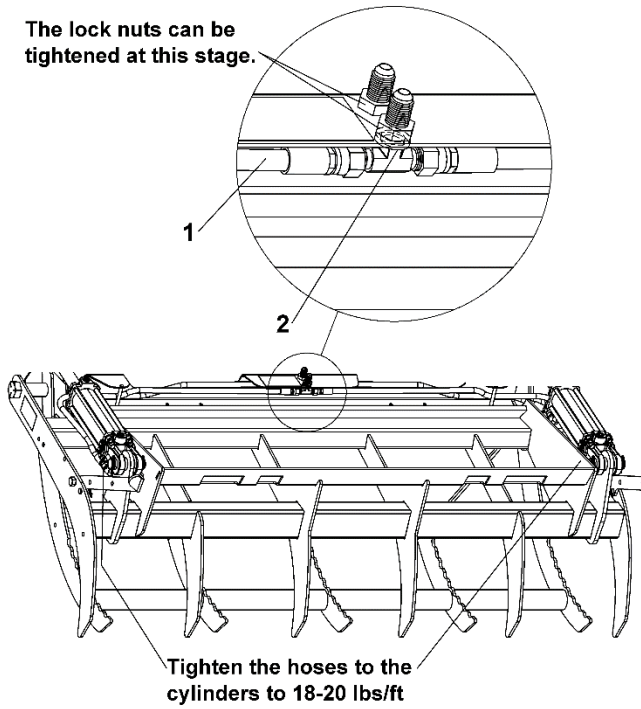

Install the other end of the cylinders to the frame.

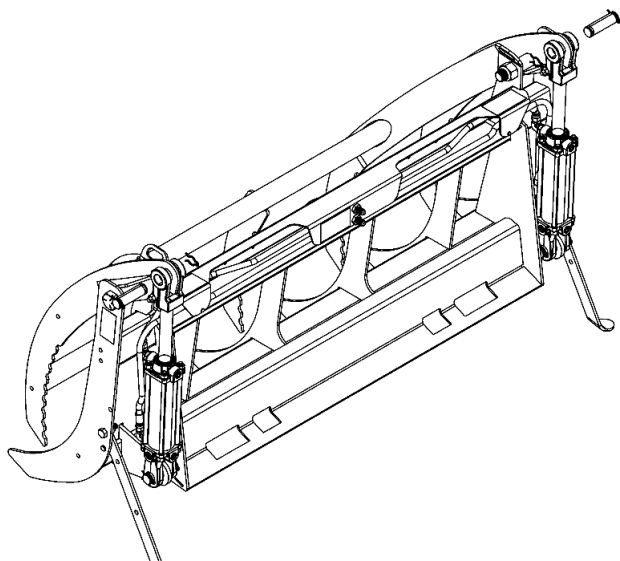

Install the hose support plates (item 1), so as to hold the hoses, using eight hex bolts. 1/4" n.c. x 1 1/4" (item 2) and nylon insert nuts (item 3). **Do not overtighten to avoid damaging the hoses.**

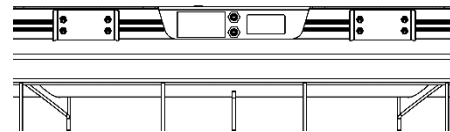
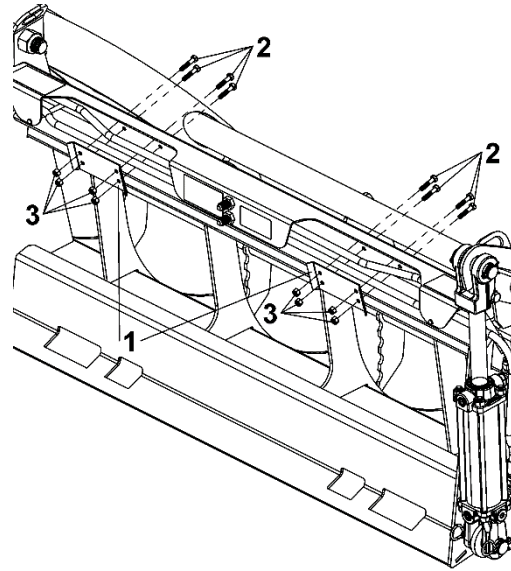

## Installation of the hydraulic hoses

On the grapple, the lower connector is to open grapple and upper connector is to close grapple

### OPTION A: Loader third function valve

Screw the hydraulic hoses (item 1) to the grapple fittings (item A) as shown, tighten to 22-24 ft-lb. Then put rubber cap of the proper color on each hose.

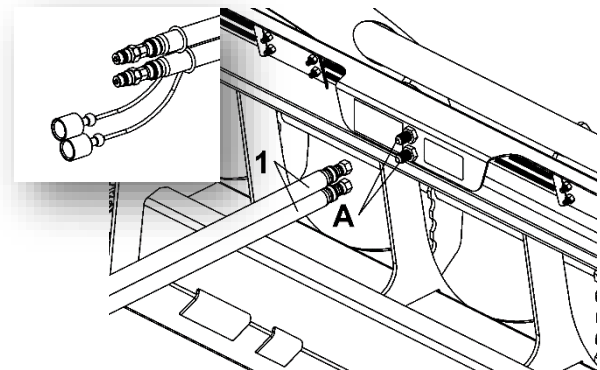

**Note 1:** You may have to change (obtain locally) the hydraulic quick connect to match your third function valve quick connect

# Assembly and initial set-up

---

**Note 2: Hydraulic hose may be too short or too long depending of tractor/loader configuration. In this case you need to obtain locally the correct hose length. Make sure hose have minimum working pressure of 3000psi and the entire hose is covered by a fabric cover. (See section hook-up equipment clearances section)**

For the installation on the tractor, see hook-up section.

## **OPTION B: Tractor do not have third function valve**

### **OPTION B1: hydraulic hose from connector to loader**

Description of the option: this option is to locale quick connect on the loader; this is to work similar to having a third function valve

- In this option you have the hose going from the tractor connector to the loader
- Then, you have the grapple with hoses and quick connect
- When installing the grapple on the loader, you just have to connect the grapple hose to the tractor hose on the loader avoiding routing the hose thru the loader and tractor frame each time.

You can obtain your hoses and quick connect locally. Make sure to have hydraulic hoses with minimum working pressure of 3000psi and the entire hose covered by a fabric cover.

Make sure to have quick connect ¼ PIONEER female on one side of the hose and the appropriate quick connect for your tractor on the other side

# Assembly and initial set-up

We also offer

Numéro ensemble	Description
700873-1	Hydraulic hose kit 16' with JIC6 female and 3/8NPTF on the other side. This kit comes with fabric cover for hoses
700872-1	Hydraulic hose kit 7.5' with JIC6 female and 3/8NPTF on the other side. This kit comes with fabric cover for hoses
700643	Quick connect kit 1/4 PIONEER female 1/4 NPTF with adaptor 3/8NPTF-F
700844	Quick connect kit 1/4 PIONEER male 1/4 NPTF avec adaptateur pour 3/8NPTF-F
700644	Quick connect kit 3/8 ISO A male 3/8NPTF F
700741	Quick connect kit 3/8 ISO A female 3/8NPTF F
700824	Quick connect kit 3/8 PIONEER female 3/8NPTF F
700827	Quick connect kit 3/8 PIONEER male 3/8NPTF F

## Option B1 assembly instruction

1. Assemble the hydraulic hoses supplied with the grapple (see option 1, for assembly instruction)
2. On hose kit or hose obtained locally, install quick connect 1/4 PIONEER female (for grapple) and on the other side the appropriate quick connect for your tractor
3. See hook-up section for hose assembly on tractor

## **OPTION B2 – hose from the accessory directly to the tractor connector**

Option description: you only have one hose from the grapple to the tractor connector

You can obtain your hoses and quick connect locally. Make sure to have hydraulic hoses with minimum working pressure of 3000psi and the entire hose covered by a fabric cover.

Make sure to have quick connect 1/4 PIONEER female on one side of the hose and the appropriate quick connect for your tractor on the other side

See option B1 for a list of offered hose and quick connect

## Option B2 assembly instruction

1. Assemble the hydraulic hoses (item 1) JIC6 female side to the grapple fittings (item A) as shown, tighten to 22-24 ft-lb.

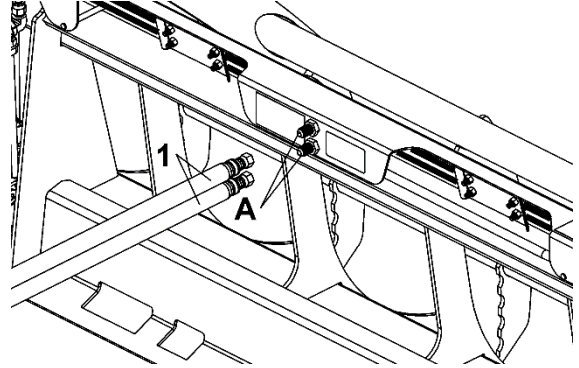

2. On the other side assemble the appropriate quick connect for your tractor
3. See hook-up section for hose assembly on tractor

## **Initial set-up**

See adjustments section for complete list of the adjustment.

## Accessory Hook-up & Unhook

### Skid steer quick attach Style

#### Hooking-Up the accessory - Skid steer quick attach style

##### DANGER

To avoid serious injury or death :

A Crushing Hazard exists when hooking-up equipment. Do not allow anyone to stand between vehicle and the equipment while hooking-up to implement. Do not operate hydraulic controls while someone is near the vehicle or implement.

##### WARNING

To avoid serious injury or death :

Make sure the skid steer style loader hitch is properly attached to the quick attach frame. It must be secured under the top angle bar and locking handles must be locked down with locking pins extending fully through the bottom slots. An improperly attached equipment can come loose and fall.

- A. Shutdown vehicle see “vehicle shutdown procedure” in the operation section
- B. Make sure all hooking components are clean and no components will interfere with hitch hook-up. If needed, pull locking handles up on loader hitch until locking pins are fully raised.
- C. Carefully drive up to the accessory making sure loader hitch is parallel with the quick attach frame (item A).
- D. Rotate top of loader hitch slightly forward.
- E. Place top of loader hitch under the top angled bars (item B) on the quick attach frame.
- F. Slowly lift loader hitch up until hitch and top angle bars on the equipment have come together.
- G. Rotate top of loader hitch back to align bottom slots (item C) in the quick attach frame with locking pins on the loader hitch.

- H. Shut down vehicle before dismounting to complete hook-up. Refer to “vehicle shutdown procedure” in the operation section
- I. Push locking handles on loader hitch down until locking pins fully extend through bottom slots (items C) in quick attach frame. Make sure locking handles are locked into position to keep pins from backing out
- J. See hose Hook-up section and electrical Hook-up if applicable

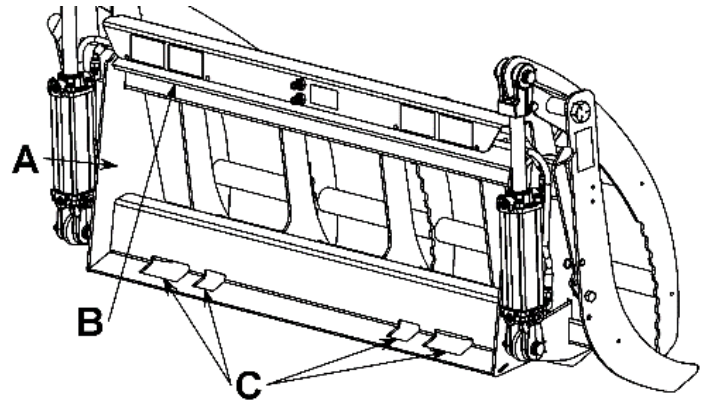

#### Check interferences

Repeat the following steps for all possible adjustments of the accessory (see adjustment section) and all possible movement of any part of the accessory which affect the position of any part of the accessory relatively to the tractor.

- A. After doing the adjustment, validate that any part of the accessory does not contact any part of the tractor
- B. Slowly move the accessory up and down and validate that any part of the accessory does not come in contact with any part of the tractor.

# Accessory Hook-up & Unhook

## Hose Hook-Up



**DANGER**

To avoid serious injury or death:

- Escaping hydraulic oil under pressure can have sufficient force to penetrate skin, causing serious personal injury. If injured by escaping fluid, obtain medical treatment immediately.
- Wear protective gloves and safety glasses or goggles when working with hydraulic system.
- Before disconnecting hydraulic line or performing work, relieve all hydraulic pressure
- Visually check for hydraulic leaks and broken, missing, or malfunctioning parts and make necessary repairs before applying pressure to the system. Do the same validation after applying pressure to the system (use a piece of cardboard not your hands to detect leaks).

### OPTION A: With third function valve:

- A. Route the flexible hoses (item 1) to the front loader third function valve (item 2), Make sure to clean tractor and accessory quick couplers.



- B. Use the appropriate control to activate the accessory,  
C. Do the Equipment clearances validation (see equipment clearances section)  
D. Purge the hydraulic system (see purging hydraulic system section).

### OPTION B1: hose from tractor connector to loader

- A. Connect the quick connect of the hose from the grapple to the quick connect of the hose previously assembled (assembly section hose assembly, option B1)
- B. If hose is not already routed from the loader to the tractor quick connect: Route hydraulic hose to the tractor hydraulic quick connect in a way to avoid damage to hose and allow movement of any components. Example: avoid any contact with any sharp edges, hot surfaces, any moving part of any component of the vehicle that may damage the hose during installation, operation or maintenance. Secure the hoses to the front loader frame.

Hint, follow the loader hydraulic hose, they are usually routed to avoid any constraint caused by loader operation

- C. Clean quick couplers and connect the quick coupler to the tractor quick couplers. Make sure this is the same coupler size and type and fully engaged.
- D. Use the hydraulic control to activate the accessory. If the movement is the opposite than what expected, switch hose on the tractor coupler.
- E. Do the Equipment clearances validation (see equipment clearances section)
- F. Purge the hydraulic system (see purging hydraulic system section).

# Accessory Hook-up & Unhook

---

## OPTION B2: hose from accessory to tractor quick connect

- A. Route hydraulic hose to the tractor hydraulic quick connect in a way to avoid damage to hose and allow movement of any components. Example: avoid any contact with any sharp edges, hot surfaces, any moving part of any component of the vehicle that may damage the hose during installation, operation, or maintenance. Secure the hoses to the front loader frame.

Hint, follow the loader hydraulic hose, they are usually routed to avoid any constraint caused by loader operation

- B. Clean quick couplers and connect the quick coupler to the tractor quick couplers. Make sure this is the same coupler size and type and fully engaged.
- C. Use the hydraulic control to activate the accessory. If the movement is the opposite than what expected, switch hose on the tractor coupler.
- D. Do the Equipment clearances validation (see equipment clearances section)
- E. Purge the hydraulic system (see purging hydraulic system section).

## Purging the hydraulic system

Hydraulic components on the accessory can contain air. The air needs to be purged from component:

- A. Raise the accessory 6" off the ground
- B. Activate the hydraulic control to cycle all possible movement of the accessory several times until the movement is stable.

## Equipment clearances



**To avoid serious injury or death caused by hydraulic hose failure**

- Its mandatory to make sure hydraulic hoses cannot be damaged: pinched, crushed, stretched... within any movement of the tractor, the loader and the grapple.

It is important to check the clearance before putting grapple into operation. Make sure hoses are long enough and won't become pinched or entangled in the equipment. Also, make sure the grapple does not come in contact with tractor frame and tires by carefully going through its full range of motions.

- A. Visually inspect hydraulic hoses for possible pinch points and shortness. Make hose adjustments before putting equipment into service.
- B. Start tractor and raise grapple approximately 12" off the ground.
- C. If necessary, have someone stand safely nearby that can motion for the operator to stop if a problem develops while completing steps D-G below.
- D. Fully extend hydraulic cylinders to pivot upper jaw fully down.
- E. Fully extend and retract loader hitch plate through its full range of motion while watching for interferences between tractor, front mounted loader, and grapple. Make sure hydraulic hoses are long enough and do not become pinched through the full range of motion.
- F. Fully retract hydraulic cylinders to pivot jaw fully up and repeat step E.
- G. Raise loader arms fully up and repeat steps D-F.

# Accessory Hook-up & Unhook

---

## Unhooking the accessory



### **WARNING**

#### **To avoid severe injury or death:**

Always store accessory on a solid flat ground with upper jaw completely closed (hydraulic cylinder completely extended) , parking stand in down position (securely attached with the hardware correctly installed). If not, the accessory can tip over

- A. Park vehicle on a solid and flat surface.
- B. Shut down vehicle (see shutdown vehicle in operation section).

Place transmission in park, set park brake, shut power equipment off, and remove switch key to avoid accidental starting. See “vehicle shutdown procedures” in the operation section

#### **Remove from Skid Steer Style Hitch:**

- A. Remove any electric or hydraulic connections if applicable
- B. Pull lock handles up to remove pins from bottom slots in hitch plate.
- C. Return to vehicle. Start vehicle and tilt top of hitch plate slightly forward toward the equipment.
- D. Slowly lower the equipment until its top angle bar and loader hitch have separated.
- E. Back vehicle slowly away from the equipment while making sure the loader hitch does not interfere with the equipment.
- F. Shutdown the vehicle See “vehicle shutdown procedures” in the operation section.
- G. Check the stability of the accessory to make sure the unit will not tip easily in any direction (forward, backward,...). If required, add support where needed to make sure the accessory will not overturn
- H. Refer to long term storage section if accessory will be stored for a long period

## Operating instructions

### Safety precaution

#### DANGER

##### To avoid serious injury or death:

- Always follow all safety precaution in the important safety information section of this manual.
- Follow all instructions and safety precautions in your vehicle manual and any other related accessory manual.
- Always follow all safety precaution on all safety decals.
- To avoid being pinned between loader lift arm or 3pts hitch and vehicle frame, always operate the accessory while seated in the operator seat with seat belt fastened.
- Keep any part of your body inside the operator area.
- Before leaving the operator's seat, lower attachment to the ground, set park brake, turn off engine and remove key.
- Do not use foot or hand control for handholds or steps.
- Keep foot and hand control clean at all times.
- Never bypass or modify a safety device.
- Keep away from electrical power lines.
- Never allow riders on vehicle or accessory.
- Operate vehicle only if equipped with ROPS with seatbelt fastened at all times.
- Check hitch fit-up frequently. An improper fit-up can result in the accessory detaching from the vehicle.
- It is the operator's responsibility to make sure nobody is in the working area before performing any work or any movement with the vehicle and accessory.
- If applicable stop loader arms gradually when lowering or lifting

#### WARNING

##### To avoid serious injury or death:

- Use the accessory for the intended purpose only. (see introduction section for product intended application).
- Do not abuse accessory.
- Do not use the accessory to lift the back or front of the tractor off the ground.
- Keep load centered at all times to avoid load shifting and help for stability.
- Do not force solid object between teeth while closing upper jaw against lower jaw.
- Never work near utilities like electrical lines, gas line...
- Do not use the accessory to pull solid object out of the ground.
- Do not attach anything to the accessory like chain to lift something or strap to hold the load in the accessory.
- Always make sure load never comes into contact with any of the hydraulic components (hoses, cylinder, fittings, ...).
- Never allow anyone to be near or under the accessory even if the accessory does not handle any load.

# Operating instructions

## Controls and display

### DANGER

**To avoid serious injury or death caused by accidental dumping scenario:**

If SCV (selectable control valve) has a regen function, it should be disabled while operating 3<sup>rd</sup> function with grapple.

For grapple opening and closing, follow the instruction of your third function valve instruction or, if you are using another tractor hydraulic output, the instruction for the control of this hydraulic output.

For the movement of the grapple, refer to your loader manual.

## Operating instructions

### WARNING

**To avoid serious injury or death:**

Counterweight may be required. Refer to your loader and tractor manual to determine if counterweight is needed. If loader and tractor manual do not have enough information, contact your tractor/loader manufacturer to determine if you need counterweight

### WARNING

**To avoid serious injury or death caused by vehicle overturn:**

Operate only with tractor equipped with an approved rollover-protective structure (ROPS) or ROPS cab and seat belt. Foldable ROPS must be kept up and in locked position at all times. Fasten seatbelt snugly and securely.

### DANGER

**To avoid serious injury or death:**

Keep attachment, loader arms, and/or load away from overhead obstructions like electrical power lines. Place an orange warning sign under overhead lines indicating type of danger above.

## Pre-start instructions

Always inspect equipment before using this equipment. Refer to section "Maintenance".

## Vehicle shutdown procedures

Always shut down vehicle before dismounting.

1. If engaged, disengage PTO.
2. Park on level surface, engage parking brake, lower attachment to the ground, turn off engine, and remove key to prevent unauthorized starting.
3. Wait for all components to come to a complete stop before leaving the operator seat.
4. Use steps, grip-handles, and skid-resistant surfaces when getting on and off the vehicle.

## Hooking-Up the accessory

See the Accessory Hook-up and Unhook section of this manual.

## Unhooking the accessory

See the Accessory Hook-up and Unhook section of this manual.

# Operating instructions

## Picking-up a load

### **WARNING**

#### To avoid serious injury or death:

- Make sure the load does not exceed tractor capacity.
- Always make sure load is centered into the accessory.
- Keep bystanders away at all times.
- Always make sure no material is reaching or close to be reaching the operator.
- Always keep load as low as possible.
- When lifting a load with the grapple, maintain the angle of the grapple so that it never tilts backwards towards the operator.

- A. Drive into the direction of the load to be picked up making sure to center the load on the grapple.

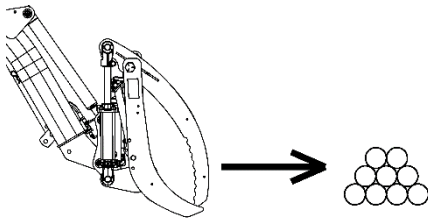

- B. Stop before being into the load zone.

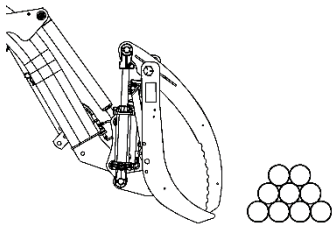

- C. Open the upper jaw at the appropriate position depending on the load size and type.

- D. Slowly drive into the material to be loaded.

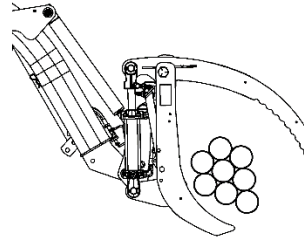
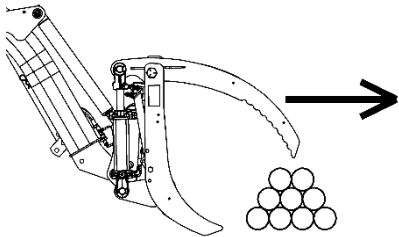

- E. Close the upper jaw to secure load. Lift slightly the load.

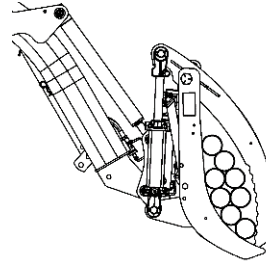

- F. Slightly drive backward and make sure the load is properly secured before travelling:
- If load is not properly secured, release load and restart the picking-up a load instruction of this section of the manual.

- G. Position load at a safe, low traveling height.

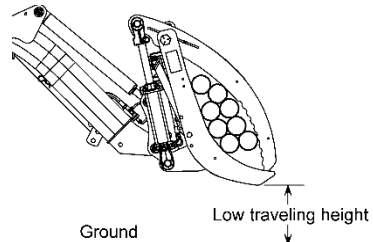

# Operating instructions

## Traveling with a load

### DANGER

#### To avoid serious injury or death:

- Do not transport on public roadways with a load in the attachment. The load can create a traffic hazard.
- Always travel straight up or straight down on incline. The heavy end of the power machine on the “uphill” side.
- Always transport loads as close to the ground as possible without hitting objects. A load carried high could shift causing the load to fall, tipping of the machine, and/or loss of control.
- Make sure you always have good visibility when travelling with the load.
- Make sure to leave enough place when turning to avoid the load hitting solid objects resulting in loss of control or property damage.
- Do not move load up and down when travelling, move load when tractor is stopped only.

- A. Making sure the load is properly secured into the accessory (see picking up a load section) travel with the lowest and safe height from the ground as possible. Also travel with the slowest speed as possible.

## Releasing a load

- A. Stop in front of desired location.  
B. Slowly raise load to required height.

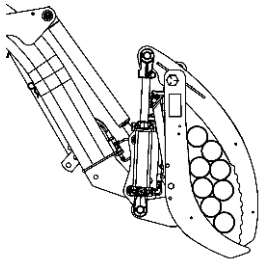

- C. Move forward slowly checking to make sure accessory and load clears all obstacles.  
D. Stop forward movement when load is positioned over its release location.  
E. Releasing load making sure you have control of the load being released at all times.

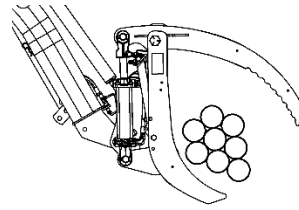

- F. Slowly and safely backup.

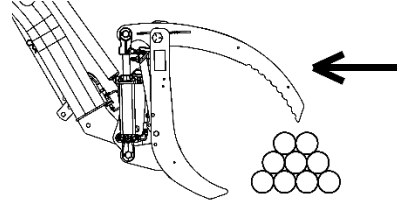

- G. Lower accessory to low as possible transporting height.

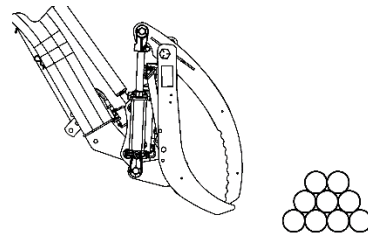

## Pull up bushes

- A. Open upper jaw around 15”.

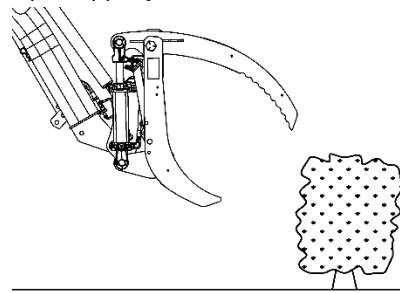

- B. Rotate front of the accessory down. Lower the accessory until upper and lower jaw become in contact with the ground on each side of the bushes.

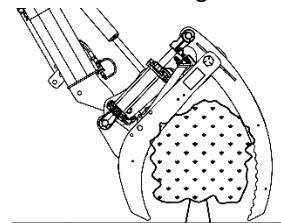

- C. Close the grapple.

# Operating instructions

---

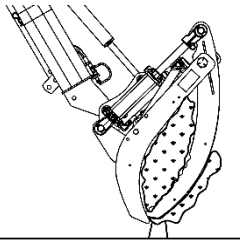

D. Raise the grapple.

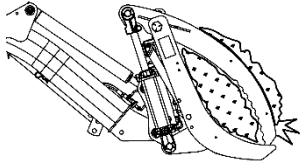

 **CAUTION**

To avoid potential damage to the grapple or tractor:

- Do not use the lower jaw to stir the soil.

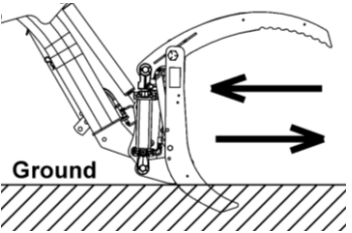

Ground

 **CAUTION**

To avoid potential damage to the grapple or tractor:

- Do not use the upper jaw to scrape the ground.

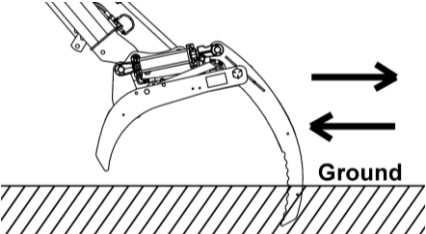

Ground

## Adjustments

### Parking stand

#### Lower the parking stands:

**IMPORTANT:** when in operation, the parking stand must always be raised at all times.

Lower the parking stands allows easy hooking and unhooking of the grapple.

- A. Raise the grapple 1" from the ground.
- B. Stop the vehicle, see the procedure for stopping the vehicle in the operation section.
- C. Remove the pins (item 1) and hair pins (item 2) then lower the parking stands (item 3 & 4) and reinstall the pins and the hair pins at the location 6.

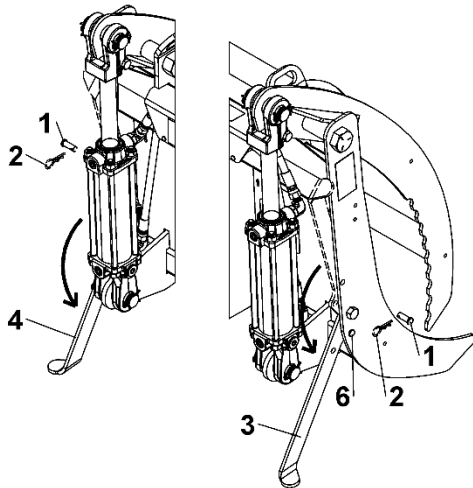

- D. Lower the grapple to the ground.

#### Raising the parking stand:

**IMPORTANT:** when in operation, the parking stand must always be raised at all times.

- E. Raise the grapple 1" from the ground.
- F. Stop the vehicle, see the procedure for stopping the vehicle in the operation section.
- G. Remove the pins (item 1) and hair pins (item 2) then raise the parking stands (item 3 & 4) and reinstall the pins and the hair pins at the location 7.

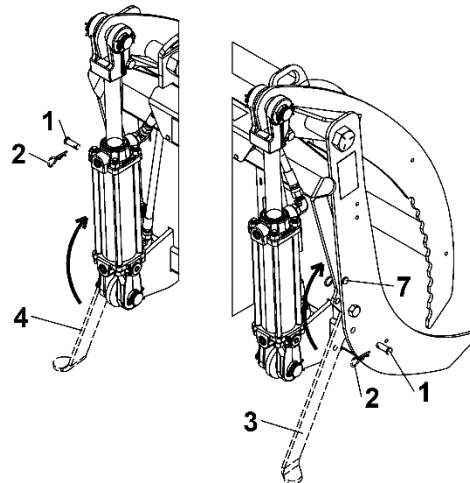

- H. Lower the grapple to the ground.

## Troubleshooting

<b>Problem</b>	<b>Cause</b>	<b>Solution</b>
Upper jaw not moving	Hydraulic hoses are not connected to tractor.	Attach couplings to tractor.
	Hydraulic hoses / fittings/cylinder are damaged.	Change damaged component.
Load is shifting	Load is being carried too high.	Travel with load as close as possible to ground.
	Traveling too fast.	Reduce speed.
	Jaw not clamped tight enough.	Reclamp the load.
	The load is not centered on the accessory.	Center the load.
	Accessory is not slightly backward to support load by the lower teeth.	Tilt the accessory backward.
	Teeth are bent.	Repair teeth.
Teeth are bending or breaking	The load is not centered on the accessory.	Center the load.
	Load is too heavy.	Reduce lifted weight.
	Impact on the accessory.	Never ram.
	Striking solid objects with the accessory.	Avoid striking solid objects.
	Abuse.	Use the accessory for the intended purpose only. (see introduction section for product intended application).
	Wedging objects between teeth with upper jaw.	Do not wedge objects between teeth and upper jaw.

## Maintenance



### **WARNING**

**To avoid serious injury or death :**

- Always follow all safety precautions in the important safety information section of this manual.
- Follow all instructions and safety precautions in your vehicle manual and any other related accessory manual.
- Use jack and support blocks to support equipment when required. Carefully release pressure from equipment with stored energy.
- Replace parts on this accessory with genuine parts only.
- Never work or walk under the accessory unless securely blocked. Otherwise accessory can fall.
- Never allow untrained personnel to service machine.

### **Maintenance schedules**

Proper servicing and adjustments are key to the long life of any attachment. With careful inspection and routine maintenance, you can avoid costly downtime and repair.

Check all bolts and pins after using the grapple for several hours and on a regular basis thereafter to ensure they are tight and secured.

Check hitch fit-up, hydraulic hoses, and fittings on a regular basis to ensure any load have not loosened the hitch connection or damaged hydraulic hoses and fittings.

Replace worn, damaged, or missing grapple parts only with genuine parts.

## Storage and transportation

### Long-Term Storage

Follow unhooking instruction in the section “Hook-up and Unhook Accessory” of this manual.

- Clean the accessory
- Inspect the accessory for loose, damaged, missing, or worn parts. Adjust and tighten loose parts. When needed replace parts with new ones.
- Repaint parts where paint is missing or worn
- Replace all damaged or missing decals
- Lubricate all lubrication points see “Maintenance and lubrication” section
- Store accessory on a level surface in a clean, dry place. Inside storage is preferable. Store where kids do not play.
- Check the stability of the accessory to make sure the unit will not tip easily in any direction (forward, backward,...). If required add support where needed to make sure the accessory will not overturn

### Transportation

Always transport the accessory empty



#### **WARNING**

**To avoid serious injury or death :**

When travelling on public roads, use SMV sign, clean reflectors, and any other device to alert others of your presence. Always comply with all federal, state/provincial and local laws

- A. If applicable, always disengage tractor / accessory PTO before raising accessory to transport position.
- B. Make sure that any part of the accessory does not contact any vehicle part when raising accessory to transport position.
- C. Travel at safe speed when transporting.
- D. Reduce tractor ground speed when turning and leave enough clearance so accessory does not contact obstacles such as buildings, trees, or fences. Turning at high speeds can result in a roll over of the tractor.
- E. Transport the accessory low to the ground to help maintain vehicle stability and visibility as much as possible
- F. Keep away from electrical power lines
- G. Shift tractor to a lower gear when traveling over rough or hilly terrain.

## Specifications

---

### Specifications

Specifications	
<b>Weight</b>	235 lbs
<b>Working width</b>	56"
<b>Closed height</b>	29 3/8"
<b>Jaw opening</b>	30"
<b>Number of teeth</b>	6 bottom & 5 top
<b>Teeth spacing</b>	10 7/8"
<b>Tooth thickness</b>	1/4" Strenx 100
<b>Hydraulic cylinder</b>	2" X 6" X 1 1/8" Rod



## Part list and parts breakdown

<b>NOMENCLATURE ET LISTE DES PIÈCES / PARTS BREAKDOWN &amp; PART LIST</b> <b>Grappin à griffe 56" #701015-2</b> <b>Claw grapple 56" #701015-2</b>				
REF.	ENGLISH DESCRIPTION	DESCRIPTION FRANÇAISE	QTY.	PART#
1	Grapple assembly	Grappin assemblé	1	501572
2	Hydraulic cylinder	Vérin hydraulique	2	109943
3	Hyd. Hose Ø1/4" x 37,5" long JIC 6 F	Flexible hyd. Ø1/4" x 37,5" long JIC 6 F	2	109985
4	Hyd. Hose Ø1/4" x 27" long JIC 6 F	Flexible hyd. Ø1/4" x 27" long JIC 6 F	2	109986
5	Hyd. Hose # 110986 assembly	Flexible hyd. # 110986 assemblé	2	110987
6	Hose support plate	Plaque de support des flexibles	2	110300
7	Hardware bag	Sac de quincaillerie	1	110305
7.1	Dust cap green	Capuchon vert	1	108527
7.2	Dust cap yellow	Capuchon jaune	1	108528
7.3	Shim	Cale	2	109962
7.4	Adapter 90deg 3/8"Male JIC x 1/2" Male ORB	Adaptateur 90deg 3/8"Male JIC x 1/2" Male ORB	4	103861
7.5	Branch Tee Bulkhead JIC 6 M w/ nut	Adaptateur de branchement en "T" JIC 6 M a/ écrou	2	109964
7.6	Hex. bolt 1/4" n.c. x 1 1/4" GR5	Boulon hex. 1/4" n.c. x 1 1/4" GR5	8	O/L (300NC.5P_1-4x1-1-4)
7.7	Nylon Insert lock Nut 1/4" n.c.	Écrou à garniture de nylon 1/4" n.c.	8	O/L (335NC.P_1-4)
8	Serial number	Numéro de série	1	REF.

O/L = Obtain Locally / Obtenir localement

Part numbers starting with 500XXX are not available for sale, however, separate parts are available for sale individually.

Les numéros 500xxx ne sont pas disponibles pour la vente. Au besoin, veuillez commander les numéros de pièces séparément.

# Part list and parts breakdown

**NOMENCLATURE ET LISTE DES PIÈCES / PARTS BREAKDOWN & PART LIST**  
Grappin assemblé #501572  
Grapple assembly #501572

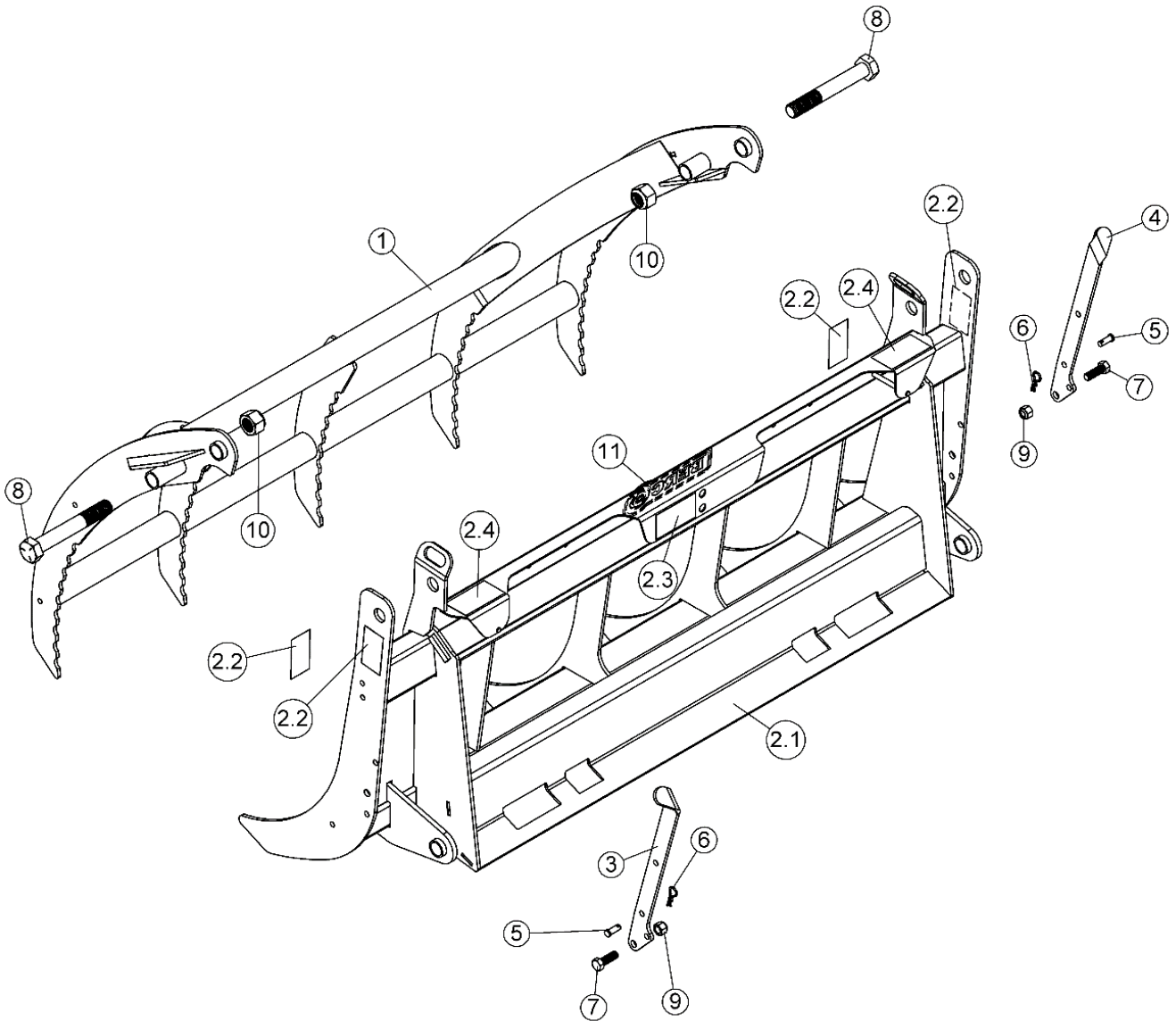

## Part list and parts breakdown

<b>NOMENCLATURE ET LISTE DES PIÈCES / PARTS BREAKDOWN &amp; PART LIST</b> Grappin assemblé #501572 Grapple assembly #501572				
REF.	ENGLISH DESCRIPTION	DESCRIPTION FRANÇAISE	QTY.	PART#
1	Jaw	Machoire	1	109974
2	Grapple frame #110303 with safety decals	Châssis du grappin #110303 a / dec. De sécurité	1	110304
2.1	Grapple frame	Châssis du grappin	1	110303
2.2	Decal Warning / Crush Harsard	Déc. Avertissement / Risque d'écrasement	4	108750
2.3	Decal Read Instructions	Décalque lire Instructions	1	109957
2.4	Decal Read Instructions	Décalque lire Instructions	2	109958
3	Left parking stand	Pied de stationnement gauche	1	110301
4	Right parking stand	Pied de stationnement droit	1	110302
5	Pin	Goupille	2	103077-Z
6	Hair pin 2.5mm	Goupille à ressort 2.5mm	2	102013-Z
7	Hex. bolt 1/2" n.c. x 1 1/2" GR5	Boulon hex. 1/2" n.c. x 1 1/2" GR5	2	O/L (300NC.5Z_1-2x1-1-2)
8	Hex. bolt 1" n.c. x 7" GR5	Boulon hex. 1" n.c. x 7" GR5	2	O/L (300NC.5Z_1x7)
9	Nylon Insert lock Nut 1/2" n.c.	Écrou à garniture de nylon 1/2" n.c.	2	O/L (335NC.Z_1-2)
10	Nylon insert lock nut 1" n.c	Écrou à garniture de nylon 1" n.c	2	O/L (335NC.Z_1)
11	Berco decal	Décalque Berco	1	102471

O/L = Obtain Locally / Obtenir localement

Part numbers starting with 500XXX are not available for sale, however, separate parts are available for sale individually.

Les numéros 500xxx ne sont pas disponibles pour la vente. Au besoin, veuillez commander les numéros de pièces séparément.

## Part list and parts breakdown

**NOMENCLATURE ET LISTE DES PIÈCES / PARTS BREAKDOWN & PART LIST**  
Flexible hyd. # 110986 assemblé #110987  
Hyd. Hose # 110986 assembly #110987

REF.	ENGLISH DESCRIPTION	DESCRIPTION FRANÇAISE	QTY.	PART#
1	Hyd. Hose Ø1/4" x 46" w/ liner	Flexible hyd. Ø1/4" x 46" a/ gaine	1	110986
2	Quick nipple 1/4" PIONEER_1/4" NPTF F.	Connecteur rapide male 1/4" PIONEER_1/4" NPTF F.	1	103237

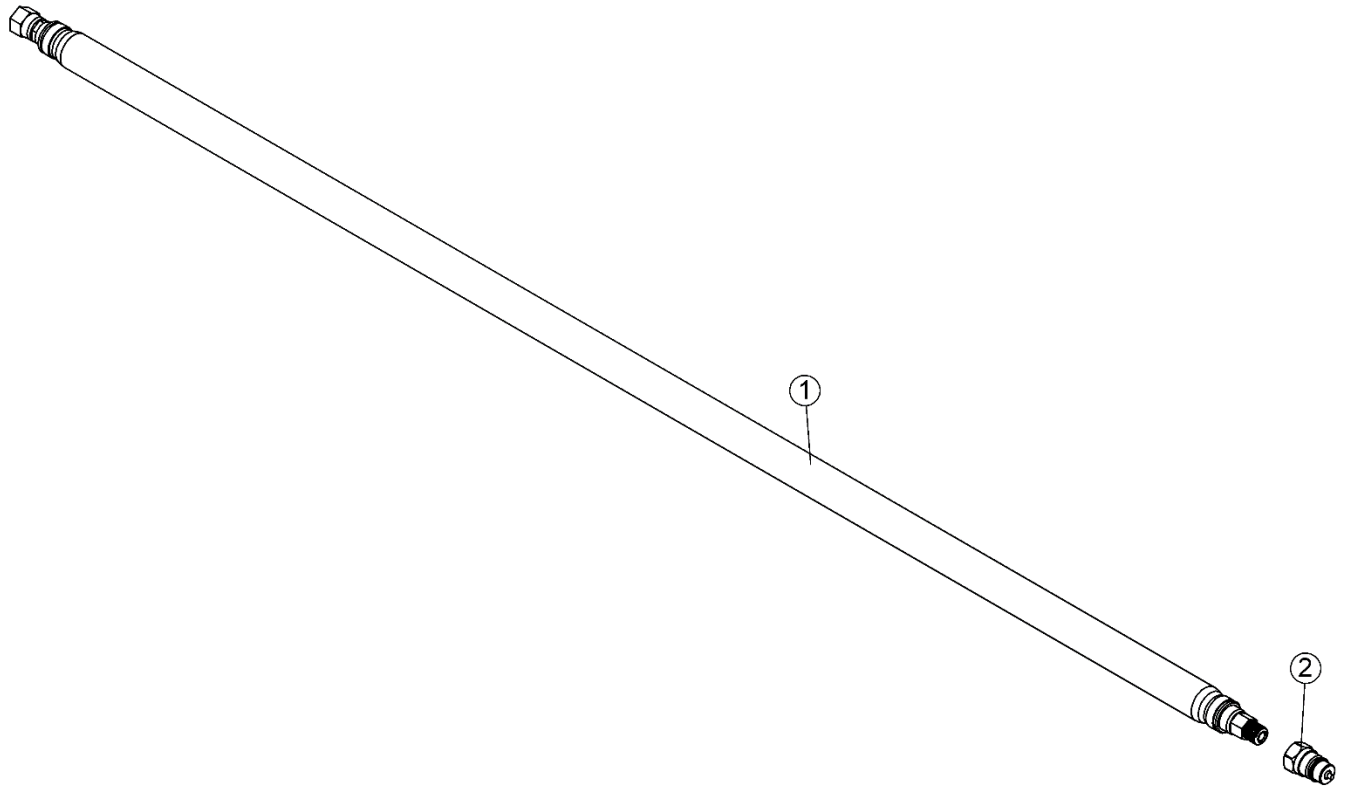

O/L = Obtain Locally / Obtenir localement

Part numbers starting with 500XXX are not available for sale, however, separate parts are available for sale individually.

Les numéros 500xxx ne sont pas disponibles pour la vente. Au besoin, veuillez commander les numéros de pièces séparément.

# Torque specification table

## Torque specification table

TO BE USED WHEN A TIGHTENING TORQUE IS NOT SPECIFIED IN THE TEXT

- The following table shows the minimum torque requirement
- Maximum is 15% more than the minimum (example: min100 Nm -> max is 115Nm)
- If specific thread is not specified in the part list or manual, the bolt thread is coarse
- N m = Newton x meter
- Ft-lb = foot pounds
- If bolt is lubricated, divide the torque value by 1.33

IMPERIAL THREAD														
Nominal Thread Diameter	Thread / inch	UNC						UNF						
		Grade 2		Grade 5		Grade 8		Thread / inch	Grade 2		Grade 5		Grade 8	
		N m	Ft-lb	N m	Ft-lb	N m	Ft-lb		N m	Ft-lb	N m	Ft-lb	N m	Ft-lb
1/4"	20	7.4	5.6	11	8	16	12	28	8.5	6	13	10	18	14
5/16"	18	15	11	24	17	33	25	24	17	13	26	19	37	27
3/8"	16	27	20	42	31	59	44	24	31	22	47	35	67	49
7/16"	14	43	32	67	49	95	70	20	49	36	75	55	105	78
1/2"	13	66	49	105	76	145	105	20	75	55	115	85	165	120
9/16	12	95	70	150	110	210	155	18	105	79	165	120	235	170
5/8	11	130	97	205	150	285	210	18	150	110	230	170	325	240
3/4	10	235	170	360	265	510	375	16	260	190	405	295	570	420
7/8	9	225	165	585	430	820	605	14	250	185	640	475	905	670
1	8	340	250	875	645	1230	910	12	370	275	955	705	1350	995
1-1/8	7	480	355	1080	795	1750	1290	12	540	395	1210	890	1960	1440
1-1/4	7	680	500	1520	1120	2460	1820	12	750	555	1680	1240	2730	2010
1-3/8	6	890	655	1990	1470	3230	2380	12	1010	745	2270	1670	3680	2710

METRIC THREAD														
Nominal Thread Diameter	Pitch (mm)	COARSE THREAD						FINE THREAD						
		Class 5.8		Class 8.8		Class 10.9		Pitch (mm)	Class 5.8		Class 8.8		Class 10.9	
		N m	Ft-lb	N m	Ft-lb	N m	Ft-lb		N m	Ft-lb	N m	Ft-lb	N m	Ft-lb
M5	0.8	4	3	6	5	9	7	-	-	-	-	-	-	-
M6	1	7	5	11	8	15	11	-	-	-	-	-	-	-
M8	1.25	17	12	26	19	36	27	1	18	13	28	21	39	29
M10	1.5	33	24	52	39	72	53	0.75	39	29	61	45	85	62
M12	1.75	58	42	89	67	125	93	1.25	58	42	95	70	135	99
M14	2	92	68	145	105	200	150	1.5	99	73	155	115	215	160
M16	2	145	105	225	165	315	230	1.5	155	115	240	180	335	245
M18	2.5	195	145	310	230	405	300	1.5	220	165	350	260	485	355
M20	2.5	280	205	440	325	610	450	1.5	310	230	650	480	900	665
M24	3	480	355	760	560	1050	780	2	525	390	830	610	1150	845
M30	3.5	960	705	1510	1120	2100	1550	2	1060	785	1680	1240	2320	1710

# Torque specification table

---

## Hydraulic fitting assembly chart

### JIC unlubricated fitting torque chart :

Dash size	JIC thread size	Torque Foot/LBS (min max)	Torque Nm (min max)
4	7/16"-20	11-13	15-17
6	9/16"-18	20-22	27-30
8	3/4"-16	37-45	50-61
10	7/8"-14	50-58	68-79
12	1-1/16" - 12	79-88	107-119

### ORB unlubricated fitting torque chart:

Lubricate Oring (not thread) before assembly

Dash size	ORB thread size	Torque Foot/LBS (min max)	Torque Nm (min max)
4	7/16"-20	13-15	18-20
6	9/16"-18	23-24	32-33
8	3/4"-16	40-43	55-57
10	7/8"-14	43-48	59-64
12	1 1/16"-12	68-75	93-101

### NPTF unlubricated fitting torque chart:

Dash size	NPTF thread size	Torque Foot/LBS (maximum)	Torque Nm (maximum)	Turn from finger tight
4	1/4	25	34	¾ - 1-3/4
6	3/8	35	47	¾ - 1-3/4
8	1/2	45	61	½ - 1 ½
12	3/4	55	75	½ - 1 ½





***WHEN PERFORMANCE  
& DEPENDABILITY  
ARE NON NEGOTIABLE!***

**Bercomac Limitée  
92, Fortin North, Adstock, Quebec, Canada, G0N 1S0**

***WWW.BERCOMAC.COM***

**PRINTED IN CANADA**

**(ORIGINAL NOTICE)**